

OPERATION, PARTS AND SAFETY MANUAL



SIGNODE®

VXT2-16/19

**TENSION-WELD®
STRAPPING TOOL**

**IMPORTANT!
DO NOT DESTROY**

**It is the customer's responsibility to
have all operators and servicemen
read and understand this manual.**

Contact your local Signode representative
for additional copies of this manual.

READ ALL INSTRUCTIONS BEFORE OPERATING THIS SIGNODE PRODUCT

SIGNODE • 3620 WEST LAKE AVENUE • GLENVIEW, ILLINOIS 60025 U.S.A.

⚠ WARNING

READ THESE INSTRUCTIONS CAREFULLY.

FAILURE TO FOLLOW THESE INSTRUCTIONS CAN RESULT IN SEVERE PERSONAL INJURY.

GENERAL SAFETY CONSIDERATIONS

1. STRAP BREAKAGE HAZARD.

Improper operation of the tool or sharp corners on the load can result in strap breakage during tensioning, which could result in the following:

- ! A sudden loss of balance causing you to fall.
- ! Both tool and strap flying violently towards your face.

Failure to place the strap properly around the load or an unstable or shifted load could result in a sudden loss of strap tension during tensioning. This could result in a sudden loss of balance causing you to fall.

Read the tool's operating instructions. If the load corners are sharp use edge protectors. Place the strap correctly around a properly positioned load.

- ! Positioning yourself in-line with the strap, during tensioning and sealing, can result in severe personal injury from flying strap or tool. When tensioning or sealing, position yourself to one side of the strap and keep all bystanders away.
- ! Using strap not recommended for this tensioner can result in strap breakage during tensioning. Use the correct Signode products for your application.

2. TRAINING.

This tool must not be used by persons not properly trained in its use. Be certain that you receive proper training from your employer. If you have any questions contact your Signode Representative.

3. EYE INJURY HAZARD.

Failure to wear safety glasses with side shields can result in severe eye injury or blindness. Always wear safety glasses with side shields which conform to ANSI Standard Z87.1 or EN 166.



4. FALL HAZARD.

Maintaining improper footing and/or balance when operating the tool can cause you to fall. Do not use the tool when you are in an awkward position.

5. CUT HAZARD.

Handling strap or sharp parts could result in cut hands or fingers. Wear protective gloves.



⚠ WARNING

6. TOOL CARE.

Take good care of the tool. Inspect and clean it daily, lubricate it weekly and adjust when necessary. Replace any worn or broken parts.

7. WORK AREA.

Keep work areas uncluttered and well lighted.

Several types of strap can be used with this tool. Use the correct Signode products for your application. If you need help contact your Signode Representative.

SAFETY PROCEDURES FOR TOOL OPERATION

1. Before using this tool, read its Operation and Safety instructions.

- ! Do not exceed the operating air pressures stated elsewhere in the manual.**
- ! Use Signode's approved filter-regulator-lubricator unit (P-008559).**
- ! Never operate a pneumatic tool with a bottled air or gas source.**
- ! For tension adjustments, follow instructions in this manual. For all other adjustments, repairs or cleaning of the tool, disconnect air supply.**
- ! This tool is a Tension Weld® type sealer. A properly made joint will appear as shown in the illustration. If the joint does not appear as shown, then the operator must proceed as follows:**



A. Insure that the tools operating instructions are being followed before applying another strap.

B. Cut the strap off and apply another.

If the joint still does not appear as shown, then inspect the tool for worn and/or damaged parts. Replace tool parts as needed. **NEVER HANDLE OR SHIP ANY LOAD WITH IMPROPERLY FORMED JOINTS.** Misformed joints may not secure the load and could cause serious injury.

- ! Tuck strap end back into the dispenser when not in use.**

CUTTING TENSIONED STRAP

Use only cutters designed for cutting strap; never use claw hammers, crowbars, chisels, axes or similar tools. Such tools will cause the strap to fly apart with hazardous force. Before using any Signode product, read its Operation and Safety Manual.

TABLE OF CONTENTS

	Page		Page
General Safety Instructions	2	Parts List, Air Motors	22
Specifications	4	Parts List, Tool	24
Pneumatic Information	5	Troubleshooting	26
Operating Instructions	9	Maintenance	30
Adjustments	11	Tool Options	31
Parts Removal and Replacement	14	Declaration of Conformity	35
Air Logic and Diagram	21		

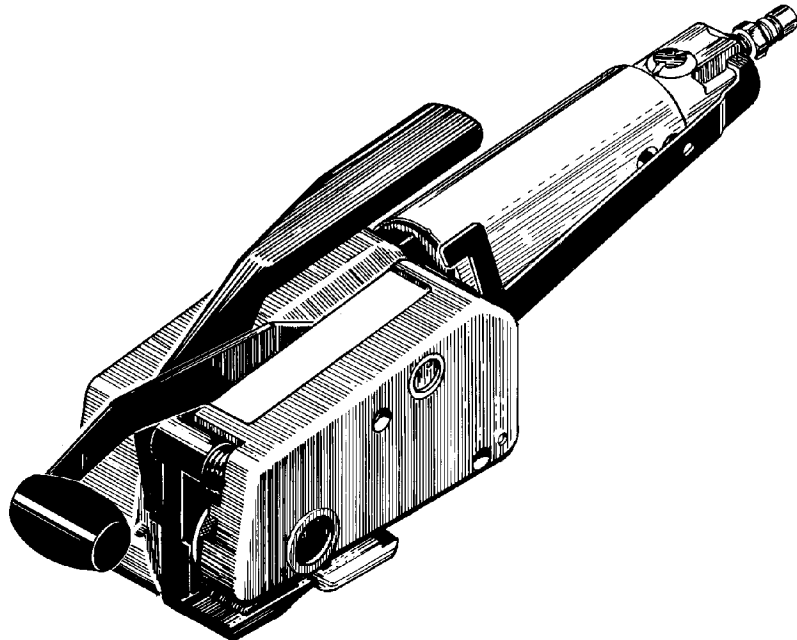

VXT2-16
Part No. 422580

VXT2-19
Part No. 422585

SPECIFICATIONS

MODEL	STRAP		
	TYPE	WIDTH	THICKNESS
VXT2-16	High Strength Tenax	16mm (.629")	0.036" to 0.044" (0.91-1.11mm)
VXT2-19	High Strength Tenax	19mm (.748")	0.045" to 0.055" (1.14-1.40mm)

NOTE: VXT2-16 tools are factory configured for use with 16mm Tenax Strapping.
VXT2-19 tools are factory configured for use with 19mm Tenax Strapping.

Re-configuring the strap size or application requirements of the tool can be accomplished by referring to page 13 of this manual.

PNEUMATIC INFORMATION

AIR PRESSURE REQUIREMENTS

The VXT2 tool is designed to operate at an air pressure of 90 psig (6.2 Bar).

AIR PRESSURE VS. PERFORMANCE

The air pressure supplied to the VXT2 tool must be a minimum of 85 psig (5.7 Bar) If the air supply pressure can be adjusted within a range from 85 psi to 90 psi (5.7 - 6.2 Bar) the VXT2 tool's performance can be fine tuned to a particular application or operation preferences. Changing the VXT2 air supply pressure to the tool will directly alter the rate at which the tool will take-up the strap slack and the strap tension. Increasing or decreasing the VXT2 air supply within the suggested 85 to 90 psig (5.7-6.2 Bar) range will not seriously affect the actual welding portion of the strap cycle.

After an initial "Break-In" period, the air motor may become more powerful. If the tool's performance is effected by this increase in performnace, reduce the air motor output by turning the adjustment screw (Key 47 on the Air Motor Assembly) counter-clockwise as required.

AIR SUPPLY INSTALLATION

If compressor has a good dryer unit, use black pickled pipe. When a dryer unit is not installed, use galvanized or copper pipe. To perform reliably, a pneumatic tool requires a continuous source of clean, water-free air at adequate pressure.



A filter-regulator-lubricator (FRL) unit must be installed as close to the air tool as possible, preferably within 10 feet. It should be placed in a convenient location where it can easily be drained, adjusted, and filled with oil. The air hose must have at least a 3/8" I.D. A quick disconnect socket fitting is installed on the stress spring end of the hose for convenient hookup to the air tool.

Filter-Regulator-Lubricator Unit
(Signode Part No. 008559 or 173111)

FRL Mounting Bracket
(Signode Part No. 071982)

Air Hose, 3/8" ID, 1/4" Fittings
(Signode Part No. 008558)

Reducer Bushing, 3/8" to 1/4"
(Signode Part No. 008478)

Quick Disconnect, 1/4" Fitting
(Signode Part No. 020706)

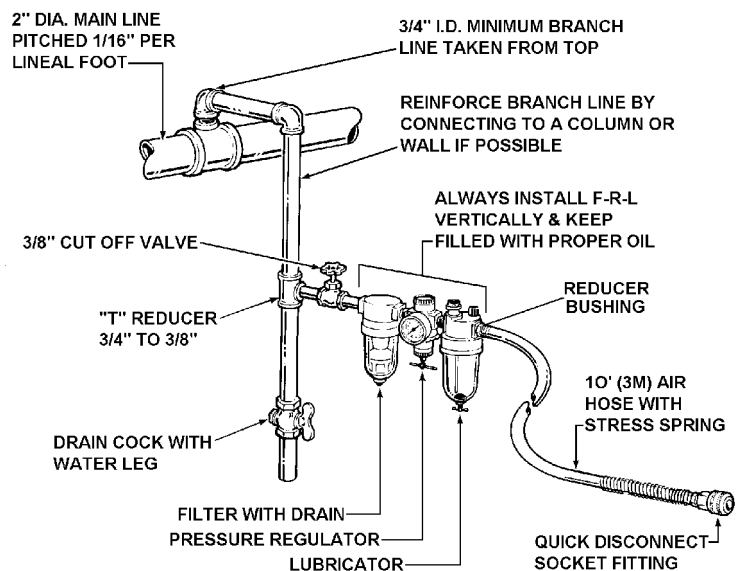

PNEUMATIC INFORMATION, Continued

Filter and lubricator bowls are made of polycarbonate material. Do not install where bowls may be exposed to materials incompatible with polycarbonate. Certain oils, solvents, and chemicals or their fumes can weaken these bowls and possibly cause them to burst. Clean only with warm water. A cut-off valve placed ahead of the filter will be useful when cleaning the filter or replenishing the lubricator.

MOISTURE

Moisture is always present in air lines due to condensation within the lines as the air cools. Steps must be taken to remove this moisture and to keep it from the air tool. This is because water tends to wash away lubricants and cause corrosion, sticking and failure of internal parts.

The main line should be pitched so the far end terminates in a water leg. Branch lines are taken from the top of the main, never off the bottom. Every branch should have a water leg at its lowest point, with a drain cock which is drained daily.

If these precautions are taken and water is still present, an after cooler and a moisture separator are required between the compressor and the air receiver tank. A large air line separator can be installed in the air tool line, but precautions must be taken to insure that it will be drained daily, before the air tool is operated.

Water in air lines is a constant threat to the proper operation of air tool. Even near freezing operating conditions, a good refrigerant type dryer is essential. A good dryer will remove 95% or more of water right at the compressor. The remaining moisture is removed at the water leg in the piping system or in the filter (Part No. 008559).

NOTE: Additional information is available in the Signode publication, "Air Supply Manual" (Part No. 186038). If you have any questions, contact your local Signode Representative.

LUBRICATION

The air motor must be properly lubricated. This is achieved by keeping the air line lubricator filled with oil and correctly adjusted. Without proper lubrication, the motor will become sticky and the tool will give low and erratic tension and be difficult to release from the strap.

Install the lubricator as close to the air tool as possible. The arrow on the lubricator's top surface must point in the direction of air flow. For proper operation, oil must drop through the lubricator sight glass at a rate of 1 to 4 drops per minute. This rate is checked while the air tool is running free. Only 20% of this oil is actually delivered to the tool. The remaining oil drops back into the oil reservoir. The unit is factory set and should require no adjustment. If an adjustment is required, the adjusting screw on top of the lubricator may be turned as marked to reduce or increase the flow of oil.

The correct grade of oil must be used in the lubricator; too heavy an oil will not provide sufficient lubrication and will cause sticking and sluggish operation of the air tool. Recommended oils are any good grade of rust and oxidation inhibiting oil with a viscosity of 80-120 S.U.S. at 100 degrees Fahrenheit. (0.15 to 0.25 cm² /sec. at 38 degrees Celsius), such as:

Non Fluid Oil Co., grade #LS-1236

Signode oil - Part No. 008556

If necessary, use SAE #5 or SAE #10 non-detergent, cut 1 to 1 with kerosene.

NOTE: Some oils contain anti-wear additives which may disable the air motor. Be certain to use recommended oil.

Several drops of lubricator oil added to the inlet of the air motor or into the air line each day will help insure good operation. A noticeable reduction of air motor performance can usually be corrected by squirting a few drops of oil into the air line.

STRAP TENSION

Strap tension is controlled by turning the adjustment screw (Key 47 on the Air Motor Assembly) in 1/4 increment turns counter-clockwise using a 3/32" hex wrench to reduce strap tension and clockwise to increase strap tension.

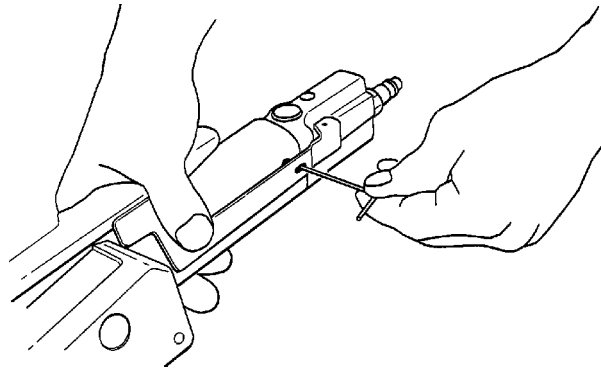

NOTE: Operating air pressure must be set between 85 and 90 psi (5.7-6.2 Bar). With accurately controlled air pressure the tension will be uniform on all straps, provided the operator allows the air motor to stall.

The VXT2-16 tool is factory tested to ensure that at least 400 lbs. (1776N) of tension is drawn at 90 psig (6.2 Bar). The VXT2-19 tool is factory tested to ensure that at least 600 lbs. (2664N) of tension is drawn at 90 psig (6.2 Bar).

⚠ WARNING

Strap breakage hazard.
Strap can break if inlet air pressure to tool exceeds 90 psig (6.2 bar).
Strap breakage can result in severe personal injury.
Maximum operating air pressure is 90 psig (6.2 bar).

AIR CONSUMPTION

Air consumption in cubic feet per minute (cfm) for the VXT2 can be calculated as follows: $cfm = (a) \times (b) \times (0.37)$

a = Number of straps applied per minute.

b = Number of seconds motor is on per strap during tensioning, from start to deceleration to stall including stall time while making joint.

0.37 = VXT2 efficiency ratio.

Example Calculation: Peak strapping load is 4 straps/min. so $a = 4$
Air motor is on 5 seconds/strap, so $b = 5$
VXT2 efficiency ratio is 0.37

$$(a) \times (b) \times (0.37) \rightarrow 4 \times 5 \times 0.37 = 7.4 \text{ cubic ft/min.}$$
$$4 \times 5 \times 0.62 = 12.4 \text{ cubic meters/hr. (12.4M}^3\text{/hr.)}$$

Air pressure is assumed to be 90 psig (6.2 Bar) with recommended size and length of air hose. Volume of air is at room temperature and sea level pressure, or so-called "free air" conditions. For more detailed information about air supply systems refer to Signode manual Part No. 186038.

COLD WEATHER OPERATION

If a tool does not operate satisfactorily in freezing temperatures, certain steps can correct the problem. The following steps can be taken to improve cold weather operation of the tool:

- a. An air line dryer adjacent to the compressor.
- b. Use lubricant recommended by Signode. Signode has tested the use of anti-freezes, none work well in air tool; the tool will gum up when anti-freezes are introduced and will not function properly. The best lubricant for freezing weather is the 1 to 1 oil and kerosene combination.
- c. If possible, run the air supply line to a indoor located Filter-Regulator-Lubricator or relocate the F-R-L to a warmer operating area.

AIR PRESSURE DROP

Confirm air pressure calibration by comparing it to a master gauge placed in-line where the quick disconnect fitting attaches to the tool.

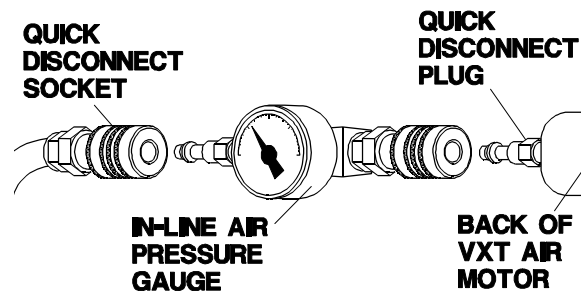

Air pressure at the tool can then be monitored as the tool cycles. Use the following information shown on the chart below for comparing the various minimum air pressures while the VXT-19 tool cycles.

If pressure readings fall below the minimums, inspect your air supply system as well as the tool for worn and/or broken parts. Contact your Signode representative if you have any questions.

AIR LINE PRESSURE MINIMUMS FOR CYCLING Tool

IN-LINE GAUGE READING PSI (BAR)			
SUPPLY/STATIC	TAKE-UP	STALL	WELDING
90 (6.2)	61 (4.1)	80 (5.4)	63 (4.2)

OPERATING INSTRUCTIONS

⚠ WARNING

Wear safety glasses.

Stand to one side of the strap when tensioning. Make sure all bystanders are clear before proceeding.

PLEASE NOTE: Do not operate tool without strap, as damage to the tool may occur.

1. With the dispenser placed behind you, bring the strap over the top and around the package, pulling out excess slack. Press the operating lever with your right hand and, with your left hand, insert the overlapped straps under the feedwheel and welding mechanism. Leave only a short tail ahead of the feedwheel and make sure straps are aligned behind the tool. Do not make a joint over a void area of the package.

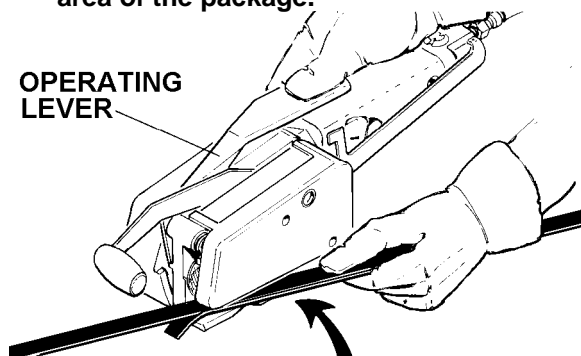

2. Recheck the strap alignment at the rear of the tool and realign if necessary. Release the operating lever and, while standing to one side of the strap line, squeeze the motor control lever to tension the strap.

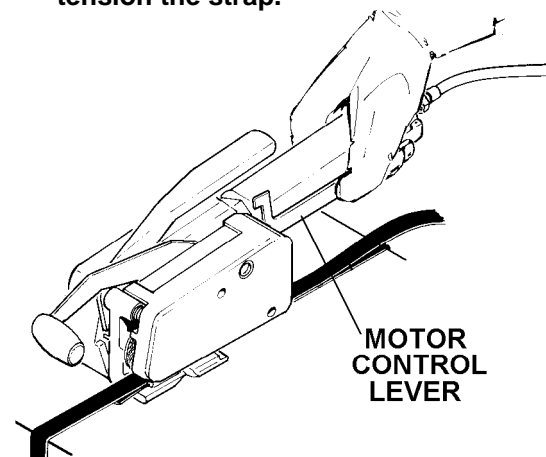

3. When the motor stalls, indicating completion of tension, continue to hold the motor lever fully closed against the motor housing and pull back the weld handle with your left hand. The handle should be pulled quickly all the way back without hesitation. When the weld lever is pulled back it traps the motor lever in the ON position.

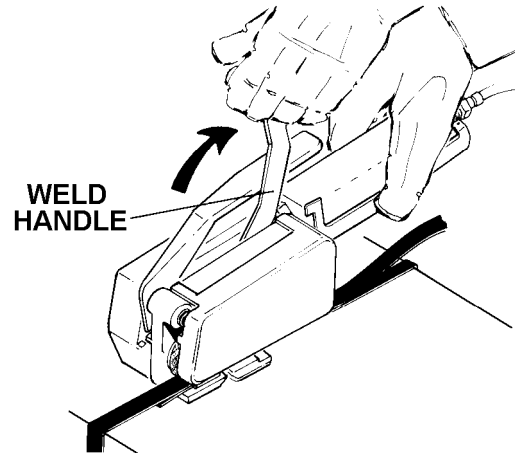

4. The internal weld timer is energized. The strap is welded and the supply end of the strap is cut-off. Pull the cut strap away during welding. The tool will continue through the weld cycle and stop with the motor lever being held in place. When the timer times out, the weld action stops. Allow the tool to remain stationary for at least 5 seconds to ensure that the weld is fully cooled.

⚠ WARNING

Failure to wait 5 seconds can result in an improperly formed joint which may lead to joint separation.

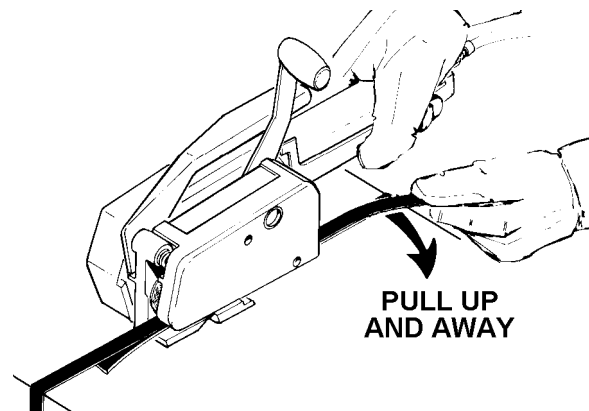

5. Push the weld handle to the forward position with your left hand. The motor lever will return to the OFF position as the weld handle is moved forward.

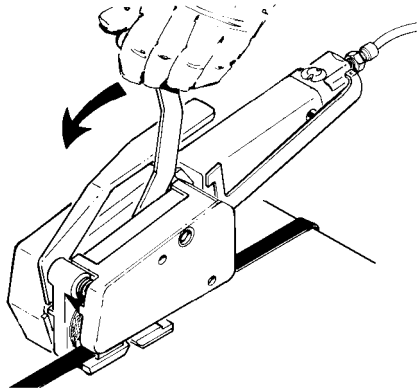

6. Press the operating lever and swing the tool off the strap, rear of tool first. Inspect the joint to make sure the straps have been properly welded.

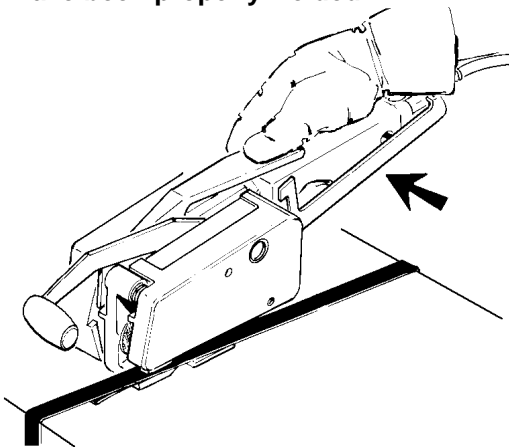

PLEASE NOTE: If the operating lever cannot easily be pressed to release the tool, momentarily tap the motor control lever using your thumb to jog the feedwheel allowing it to roll back, releasing it and the tool from the tensioned strap.

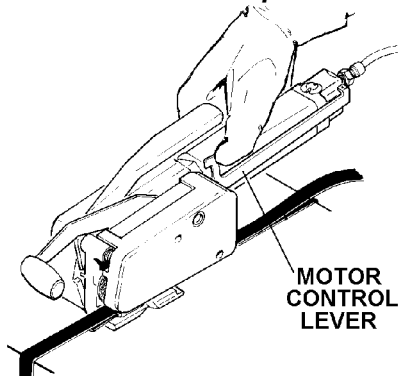

SEALING OPERATION

This tool is a Tension Weld® type sealer. A properly made joint will appear as shown in the illustration. If the joint does not appear as shown, then the operator must proceed as follows:

1. Insure that the tool operating instructions are being followed before applying another strap.
2. Cut the strap off and apply another.

A good weld will show some material displacement along the edges.



The welded area should extend the full length and width of the gripper impression.

If the joint still does not appear as shown, then inspect the tool for worn and/or damaged parts. Replace tool parts as needed. **NEVER HANDLE OR SHIP ANY LOAD WITH IMPROPERLY FORMED JOINTS.** Misformed joints may not secure the load and could cause serious injury.

TOOL ADJUSTMENTS

WELD TIME

Weld time has been factory adjusted to provide acceptable weld strength when using High Strength Tenax (polyester) type strap.

Weld time may need to be adjusted due to air supply differences, tool wear, etc. Adjustments are made by turning the small slotted screw, located beneath the weld housing at the rear of the tool, using a small screwdriver. Turn the screw clockwise to increase weld time and counterclockwise to decrease weld time.

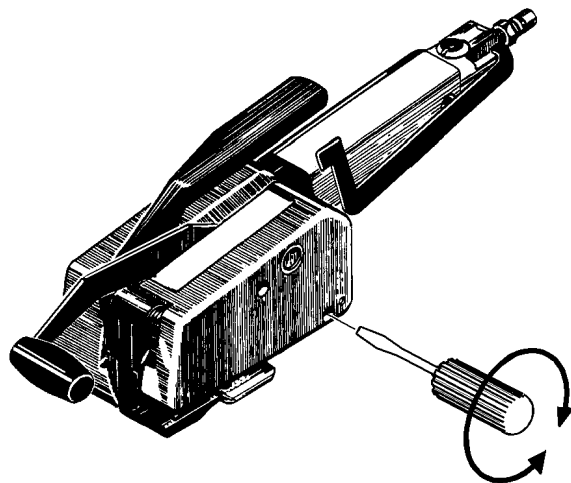

CW INCREASES TIME
CCW DECREASES TIME

Establishing the correct weld time is a matter of trial and error and should be conducted as follows.

1. Adjust the screw in 1/8 to 1/4 turn increments only.
2. Apply a strap and make a weld.
3. Compare the weld made with the illustrations shown on page 11 of this manual. A good weld will displace some material along the outer edges of the joint.
4. If you are unable to produce an acceptable joint or if you have any questions as to whether your tool is producing good weld strength, contact - your Signode Sales Representative.

CUTTER ADJUSTMENTS

When the strap cutter begins to wear or strapping seems difficult to cut off the strap cutter may need adjustment. Contact the Signode tool repair center or your Signode representative for information on accessing the adjustment screw.

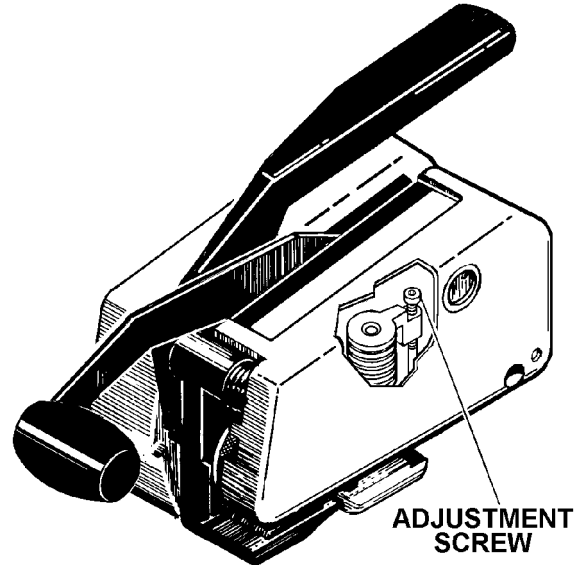

Adjust the cutter by turning the adjustment screw inward (clockwise) or out (counterclockwise) using 1/8 turn increments. Run one or more tool cycles and continue to adjust as necessary until proper strap cut-off has been obtained.

NOTE: Do not over tighten cutter mechanism as lower strap damage or poor strap cut-off will occur.

FEEDWHEEL TO GRIPPER PLUG

The feedwheel to gripper plug clearance may require readjustment if the feedwheel, tensioner foot or gripper plug has been replaced. The feedwheel clearance should also be inspected during routine tool maintenance procedures. Adjust the feedwheel clearance as follows:

1. Open the tensioner foot and place 1 to 2 layers of .002", 1/2" wide (.05 x 12mm) shim stock between the feedwheel and the gripper plug. **NOTE:** Using a single .004" (.10mm) shim is not recommended because a single thicker shim may not conform to the feedwheel shape, resulting in inaccurate clearance measurements.

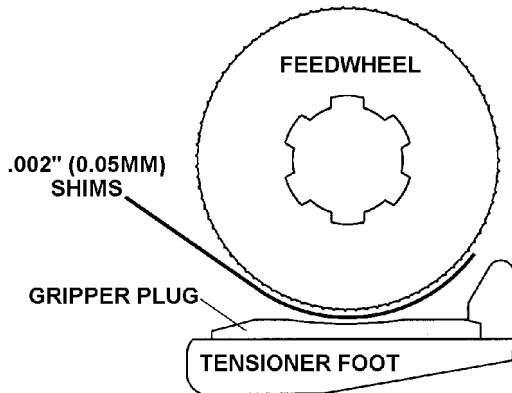

2. Release the tensioner foot to pinch the shims between the feedwheel and the gripper plug. Holding the shims with one hand, jog the air motor on and off to rotate the feedwheel at least one full revolution. If properly adjusted the tool should lightly tug at the shims while rotating. Clearance between the feedwheel and gripper plug at this point should fall between .002"-.004" (.05-.10mm).
3. If the feedwheel needs to be adjusted, use a 3/32" hex wrench to rotate the adjustment screw located in the tensioner foot.

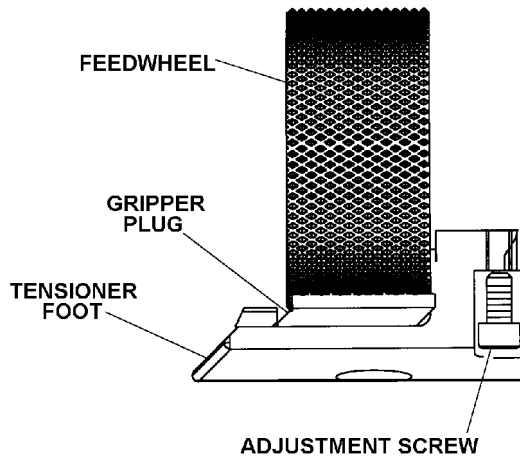

Turn the adjustment screw clockwise for greater clearance and counter-clockwise for less clearance. Turn the adjustment screw only in 1/8 turn increments. After each 1/8 turn, repeat the adjustment testing as described in step 2.

4. Once the proper clearance has been found the tool can be returned to service. **NOTE:** Never turn out the adjustment screw more than 1/8 turn at a time without testing or completely removing the adjustment screw. These actions will severely damage both the feedwheel and gripper plug.

VXT2 STRAP SIZE CONVERSION

To convert (re-configure) a VXT2-16 to a VXT2-19 or vice versa, two operations must be performed.

1. The two inner guides (Key 103) must be re-positioned (rotated) by loosening the mounting screw (Key 104) and rotating the guide 1/2 turn. The strap should then appropriately contact the guide edge marked "16" or "19".

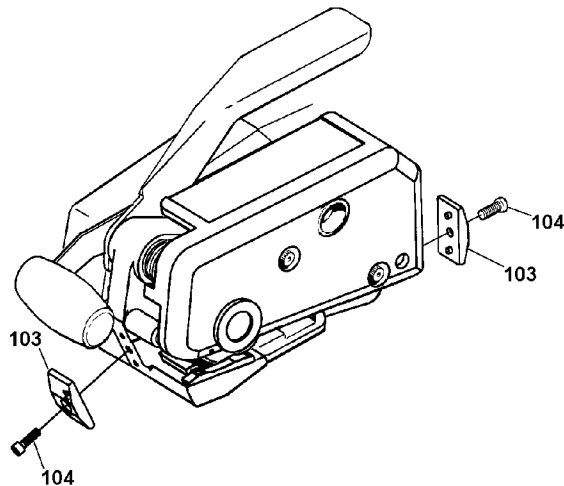

2. The guide spacer (key 105) must also be repositioned for the appropriate strap size. Squeeze the tensioner foot lever to expose the SHCS (Key 104) on the tensioner foot. Temporarily remove this screw. Remove the guide spacer (Key 105) from the tool. Reposition the guide spacer between the feedwheel and the guide plate for 19mm usage. Position the guide spacer between the guide plate and the weld housing for 16mm usage.

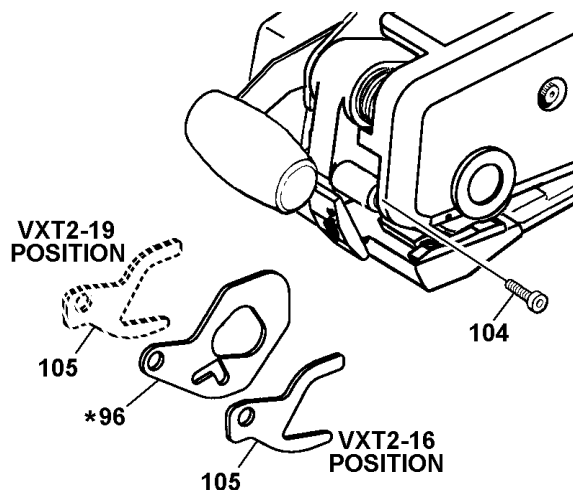

* Guide plate (Key 96) can not be removed from tool. It is shown as is for clarity only.

PARTS REMOVAL AND REPLACEMENT

FEEDWHEEL AND GRIPPER PLUG

1. Place the tool on its side and remove the two socket head cap screws (75) from the weld housing (24).
2. Pull upward on the weld housing and raise it slightly.
3. Insert a thin rod or screwdriver and disengage the torsion spring (23) from the tab on the weld housing (24).
4. Pull the weld housing off the tool.
5. Lift the guide plate (96) and feedwheel (22) from the feedwheel shaft (21).
6. Lift the torsion spring (23) and the tensioner foot (16) off the support pin (25). This allows the gripper plug (17) to be replaced if necessary. Turn the tensioner foot over, remove the flat head cap screw (19) and with a small punch, drive the roll pin (20) upward to remove the gripper plug and strap guide, (18).
7. Replace the feedwheel if necessary, making sure the smooth face of the feedwheel faces inward.
8. Lubricate the support pin and the end of the feedwheel shaft with Mo-Lith No. 2 lubricant to allow the tensioner foot to pivot freely.
9. Reassemble the parts in reverse order if further parts removal and replacement are not needed.

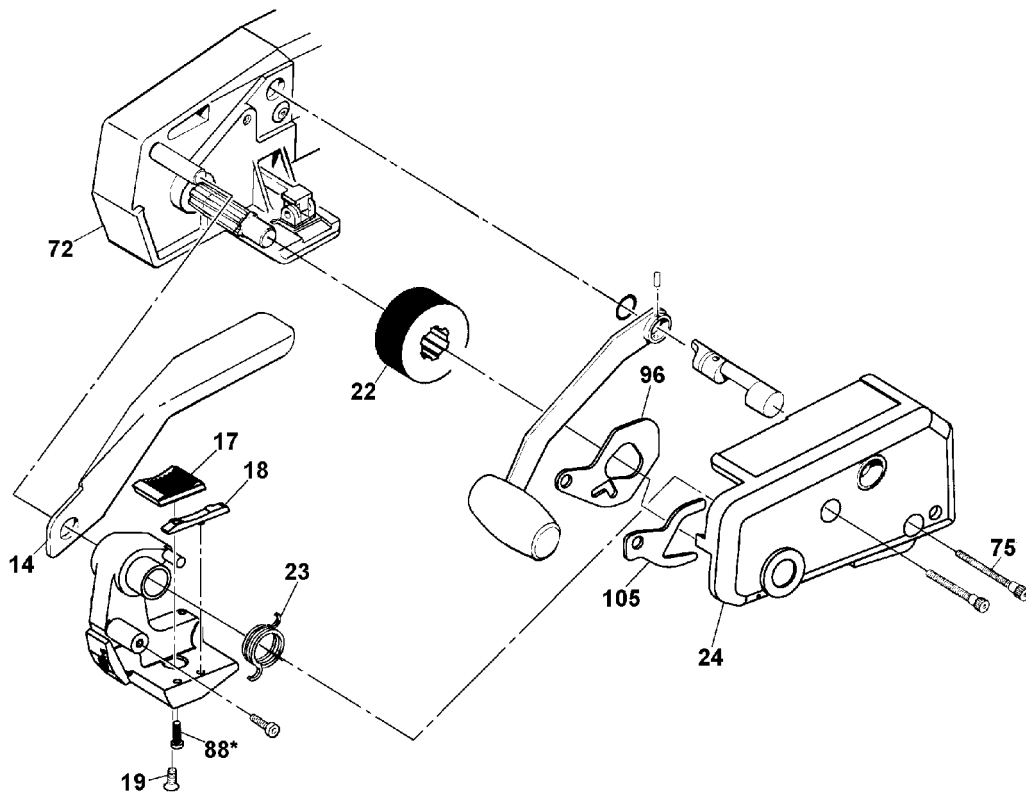

CUTTER BLADE

1. Place the tool on its side and remove the two socket head cap screws (75) from the weld housing (24).
2. Pull upward on the weld housing and raise it slightly.
3. Insert a thin rod or screwdriver and disengage the torsion spring (23) from the tab on the weld housing (24).
4. Pull the weld housing off the tool.
5. Remove the three socket head cap screws (76) that hold the motor mount (41) to the tool.
6. Separate the motor mount from the tool. Lift the cutter blade (46) from its pivot pin (74).
7. Examine the cutter blade (46), spring (84) and pin (74) for a worn or damaged areas. Replace if necessary.
8. Reassemble the tool in reverse order, except for the small compression spring if further parts removal and replacement is not required.

Refer to page 23, assemble the clutch spring (36) and the clutch (37) on the spline of the Spiroid worm and press down to weld position. Remove the weld handle subassembly from the weld housing and insert it into the gear housing in the sealing position. The cam on the pressure eccentric will be engaged with the groove of the clutch. This will hold the clutch assembly in place when reassembling the tool.

9. Lift up the cutter blade and gently insert the compression spring into the cavity found on the underside of the cutter blade.

CAUTION

A small compression spring (84) is contained under the cutter blade. Use care in removing the two halves of the tool so as not to damage or lose the spring.

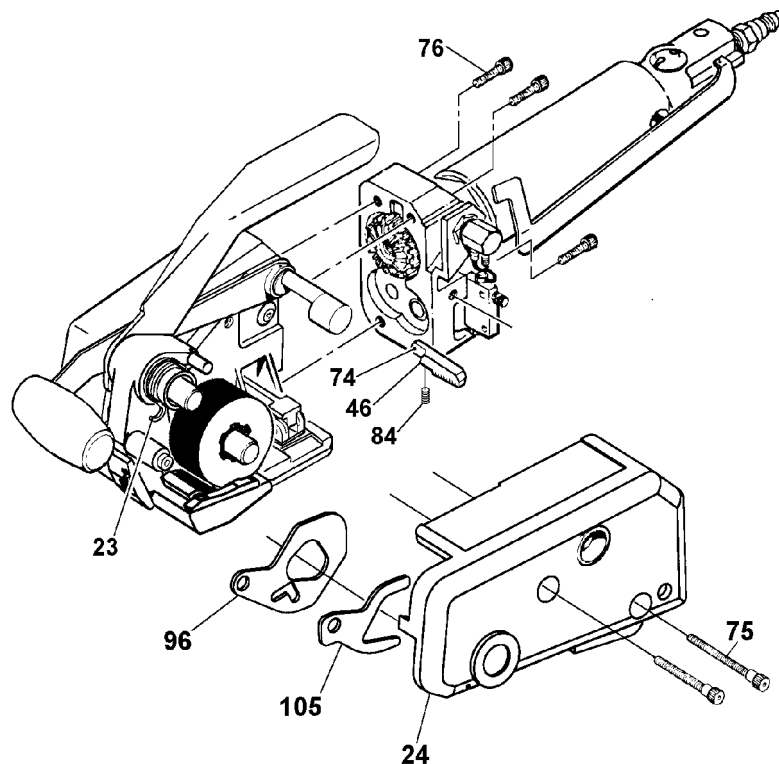

WELDING MECHANISM, DRIVE GEARS, CLUTCH AND BRAKE

1. Remove the idler gear (27) from the pin (30) and examine both parts for wear.
2. Remove the eccentric shaft (26) and examine it for wear.
3. Lift the slider link (48) from the gear housing (72). Examine the teeth on the upper gripper (52) for wear. The upper gripper can be replaced by removing the pin (51). Make sure the pin faces the teeth of the upper gripper (52) as shown.
4. Remove the needle bearing (29) from the casting by threading a 1/4-20 screw through the bearing into spacer (86). Clamp the screw head in a vise and lightly tap the casting to extract the bearing (See inset "A").
5. Examine the teeth of the lower gripper (78). If the part is to be replaced, it may be removed by first removing the mounting screw (87) from underneath, then punching it out from underneath through the two holes. When reinstalling a lower gripper, use Loctite "380 Black Max" (Signode Part No. 274111) or an equivalent instant adhesive to ensure the lower gripper will be held securely. Note that mating surfaces must be free of dirt and grease.

NOTE: When using 380 Black Max adhesive, directly follow the manufacturers cleaning and preparation instructions.

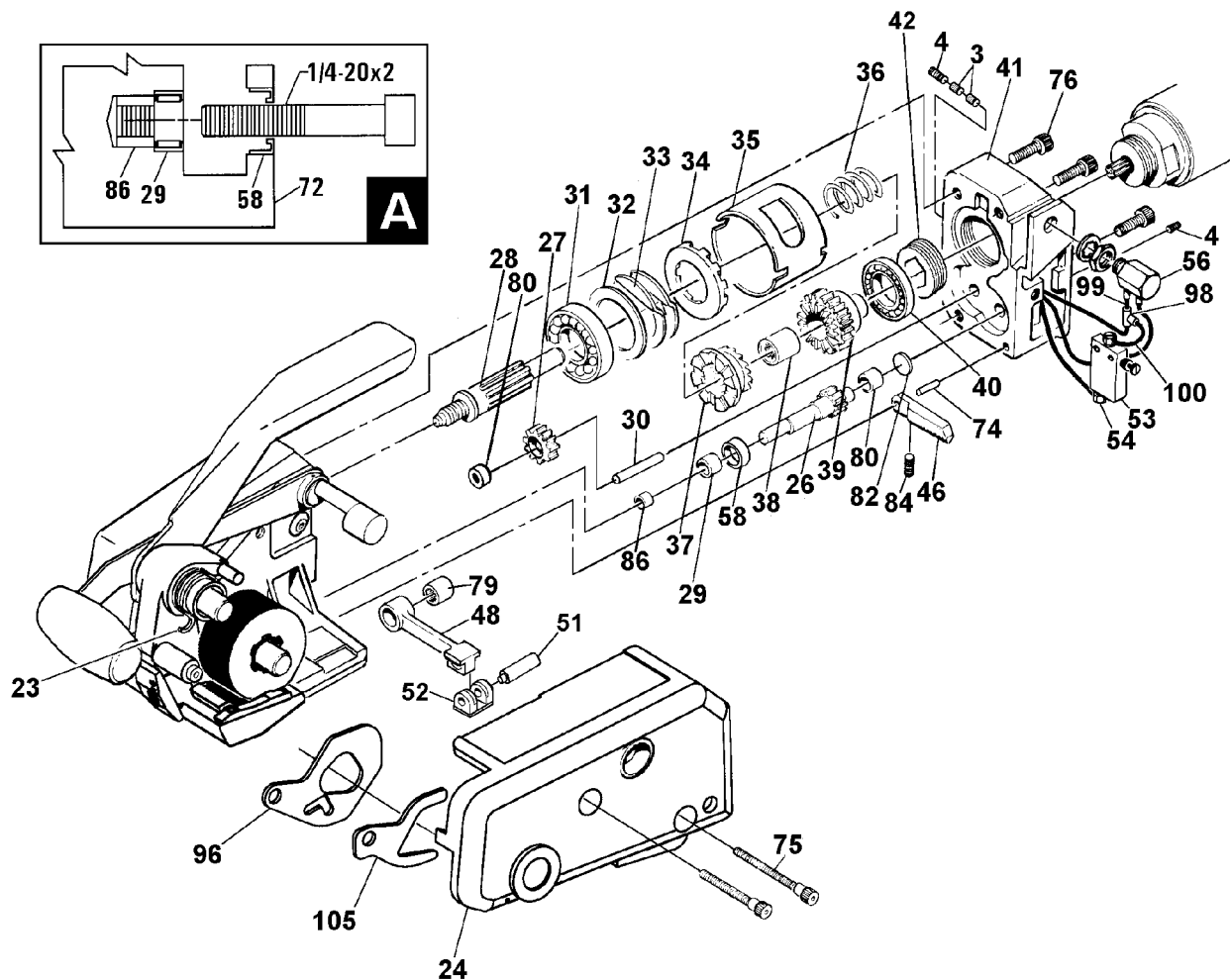

CLUTCH AND BRAKE

1. You now have access to the clutch (37) and the drive gear assembly (39). Normally, the drive gear will remain in the motor mount and can be removed by pulling it straight out. The clutch will be loose in the gear housing as the spring behind the clutch forces it outward.
2. With these parts removed, wipe out all the surrounding grease to remove any metal chips that may be present. The idler gear (27) and the eccentric shaft (26) have been previously removed to facilitate cleaning and allow repacking of the needle bearings (29, 80) in the gear housing and motor mount prior to reassembly. Check idler gear pin (30) for wear. This portion of the tool is to be repacked about 50% full with Non-fluid Oil No. K-55 (Signode Part No. 177029).
3. Check the teeth of the clutch (37) and the drive gear assembly (39A) for wear. Replace if necessary. Also, check the needle bearing (38) in the center of the drive gear for wear and make certain the needles turn freely.

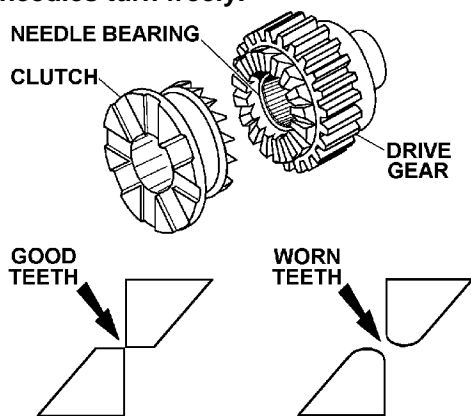

4. With a moderate amount of grease added, a new clutch can be installed on the spline of the Spiroid worm (28) and a new drive gear assembly (39A) can be installed into the motor mount.
5. Remove spacer sleeve subassembly (32, 33, 34, and 35). Disassemble by grinding or filing the two stakes, if necessary. Replace the brake (34). Make certain that the flat surface of the brake is facing the brake springs (33) and insert the springs with the concave side towards the washer (32). Stake the spacer sleeve twice and replace the spacer sleeve subassembly.

6. Assemble the clutch spring (36) and the clutch (37) on the spline of the Spiroid worm and press down to weld position. Remove the weld handle subassembly from the weld housing and insert it into the gear housing in the sealing position. The cam on the pressure eccentric will be engaged with the groove of the clutch. This will hold the clutch assembly in place when reassembling the tool.
7. Add lubricant to the drive gear assembly (39A) and insert it into the motor mount (41). Also add lubricant to the idler gear (27) and the eccentric shaft (26) then insert them into the tool. Reassemble the motor mount to the gear housing and secure it with the three socket head cap screws.
8. Refer to the illustration on page 27. Examine the small dowel pin (50) that sits in the groove in the contact stem (44), for wear. Replace if necessary. Liberally lubricate with MO-Lith No. 2. This will also hold the pin in place during reassembly. Remove the weld handle from the tool and reassemble it into the weld mechanism with the following components. Inspect and replace the parts as needed and add lubricant:

- ! Pressure eccentric (66)
- ! Lift tab (49)
- ! Compression plate (43)
- ! Die spring (45)
- ! Shim (81)
- ! Contact stem (44)
- ! Dowel pin (50)
- ! Weld housing (24)

Examine the bushings (64 and 65) in the weld housing (24) for wear and replace as required.

9. Check the valve components for cut tubing or loose fittings, reassemble all parts, being careful not to crimp or pinch the tubing, and operationally test the tool.

AIR MOTOR

This tool is manufactured with one of two available air motors. Inspect the air motor housing to determine which specific air motor instructions to follow. The two motors available for this tool are part number 422525 and 423900.

WARNING

Make sure the air line has been disconnected from the quick disconnect plug before attempting the following procedures. Failure to disconnect the air may result in personal injury.

1. Remove the valve housing (36) by removing the three socket head cap screws (32). Remove the lower cover (31) by removing the two mounting screws (37).

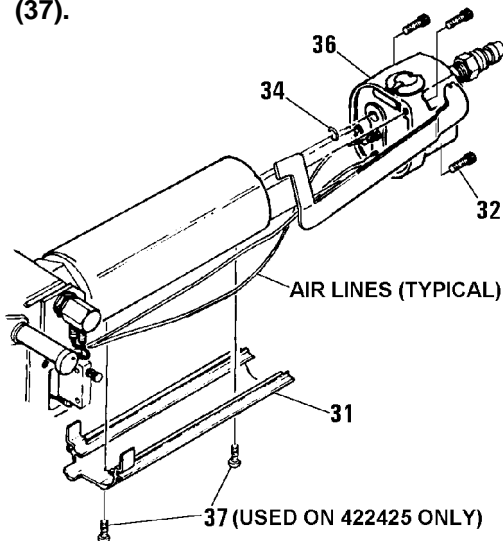

2. Swing the valve housing (36) to the side, being careful not to damage the air lines. Remove the O-ring (34) from the end of the air motor housing. Set it to the side for reuse.
3. Remove the three socket head cap screws which secure the motor mount to the gear housing.

CAUTION

A small compression spring (84) is contained under the cutter blade.

Separate the motor mount from the gear housing and remove the drive gear and bearing.

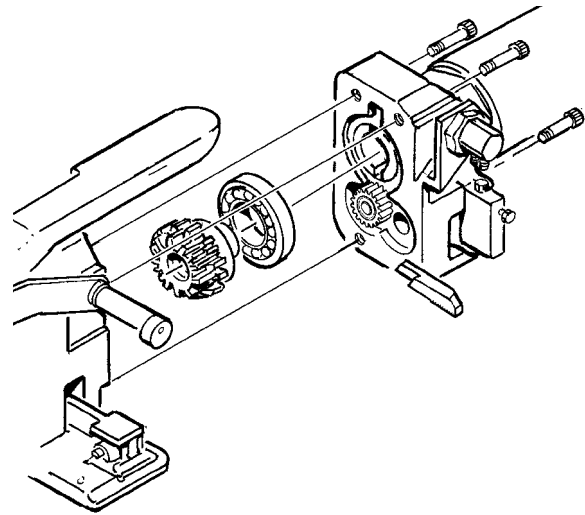

4. Remove the locking ring from the motor mount. NOTE: The locking ring has left-hand threads.

NOTE: Use of Assembly Fixture (Part No. 306871) may be useful in removing the locking ring. This fixture allows the air motor to be clamped in a secure position while the locking ring can be removed with the accompanying special 5/8" hex adapter (Part No. 422340).

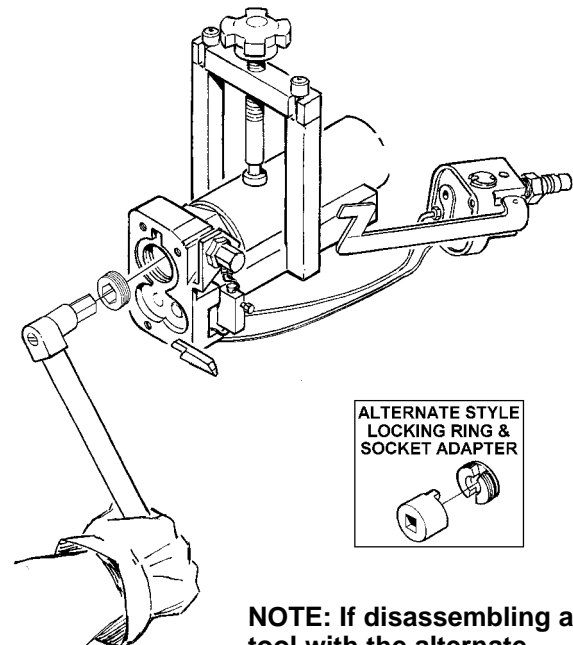

NOTE: If disassembling a tool with the alternate style locking ring, use socket adapter Part No. 422341.

5. Turn the air motor assembly clockwise to separate it from the motor mount.
NOTE: The air motor has left-hand threads.
6. Unscrew the gear housing (30) from the motor housing.
7. Slide out the cylinder (15) from the motor housing (11). When reinstalling the cylinder in the motor housing be sure to line up the alignment pin (16) with the aligning mark on the housing. This will ensure that the alignment pin will slip into the correct hole in the bottom of the motor housing.

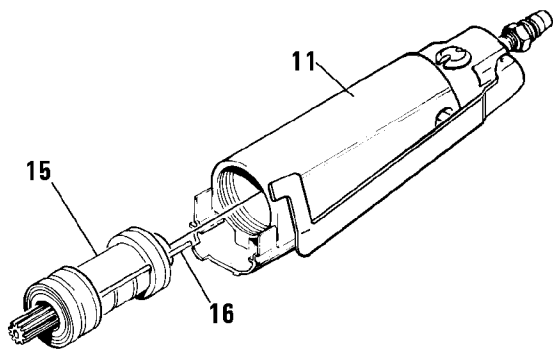

8. Remove each of the idler gear assemblies (23) from the cage (24). Check the idler pins, the bushing in the center of the idler gear, and the pinion shaft teeth for wear. Replace if necessary.

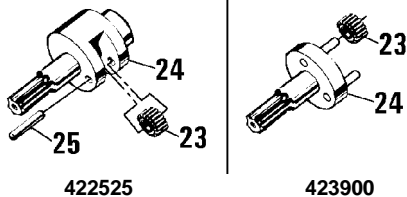

9. Remove the aligning pin and tap on the end of the rotor (18) to loosen the assembly.

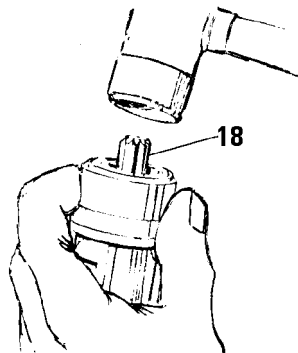

10. Disassemble the rotor by sliding off the front end plate (20), and the two ball bearings and spacer (21, 22). Then slide the back end plate (14) and the rotor assembly (18), with the vanes (17), out of the cylinder.

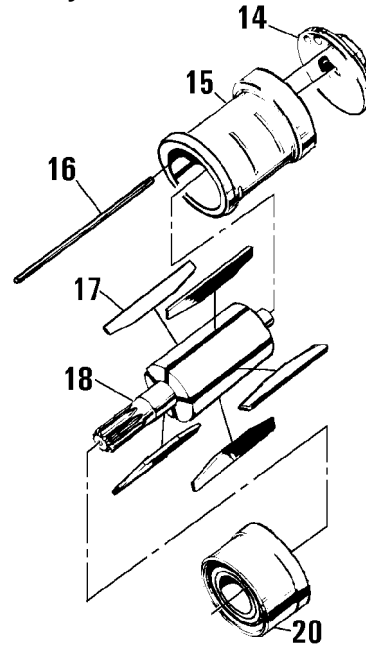

11. Look for areas of wear on the face of the end plates, the pinion teeth on the rotor and the edges of the vanes. The vanes must be kept clean to float freely in the rotor. **Note:** If the vanes and/or the idler assemblies have to be replaced, they must soak in air line oil overnight before assembling them into tool.
12. Once these parts have been examined, cleaned and worn parts replaced, the air motor may be reassembled. Keep in mind the care required when reassembling the alignment pin.
13. Temporarily install the O-ring (34) and the valve housing assembly to the air motor housing.
14. Add several drops of air line oil to the motor. Lightly clamp the air motor into a traditional vise. Connect air to the motor at 20 psig and press the motor lever. The motor must start and turn freely. With the motor running, carefully tighten the gear housing (30) by turning clockwise and note the speed increase to peak RPM using 275-450 in. lbs. of torque. Do not over tighten as this will slow down the motor. Disconnect air supply.

15. Remove the air motor from the vise. Clean the motor mounting threads with an appropriate solvent, also clean the threads of the motor mount. Remove the valve housing assembly and O-ring from the air motor.
16. Place a few drops of Loctite #242 sealant on both the external threads of the air motor and the internal threads of the mount. Screw the air motor into the motor mount until fully seated. Back out the air motor only enough to align the motor to the mount when placed into the assembly fixture.
17. Place the air motor and mount into the assembly fixture. Make sure the pin which extends out from the base of the fixture is properly aligned into the cavity found in the rear of the motor mount. Securely clamp the motor in place.
18. Using an inch-pounds torque wrench, install the locking ring to 450-550 in-lbs. (50-60 Nm) of torque.

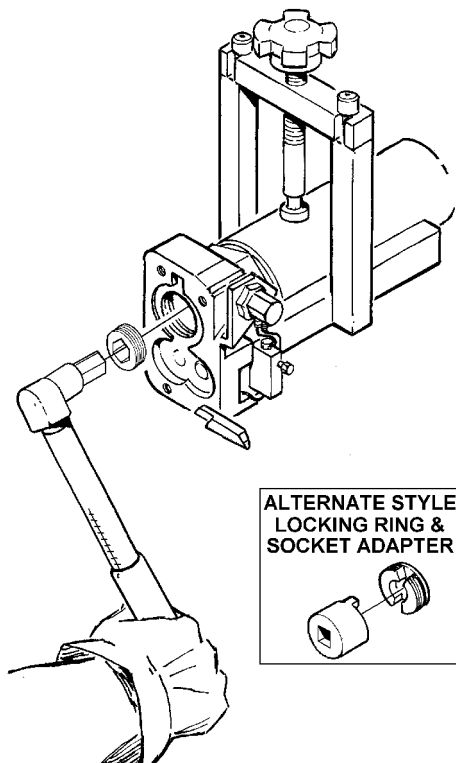

19. Continue to reinstall the O-ring, valve housing assembly, drive gear, bearing and lower air motor cover.
20. The air motor/mount assembly can now be mounted to the gear housing assembly.

21. Lift up the cutter blade and install the small compression spring (84).

AIR MOTOR VALVE

Remove the air valve as follows:

1. Remove the Truarc ring (4), permitting removal of the valve sleeve (5), stem (7), and spring (9).
2. Clean all parts to be sure any dirt causing sticking of the valve is removed.
3. Replacing the O-rings (6, 8) should correct any leaking air. Oil lightly and replace the parts as disassembled.

Remove the pilot valve as follows:

1. Remove the valve cap (35) using cap tool (P/N 442449). Lift out the spring and pull out the pilot valve (33) from the valve housing (36).
2. Replace the pilot valve assembly if necessary, being careful not to cut the "O" rings. Wipe a small amount of air line oil on the "O" rings and install the pilot valve and spring into the housing. The pilot valve cannot be disassembled. Replace it as a unit.
3. Install the valve cap using the cap tool to 30-40 in-lbs. (3-5Nm) of Torque.

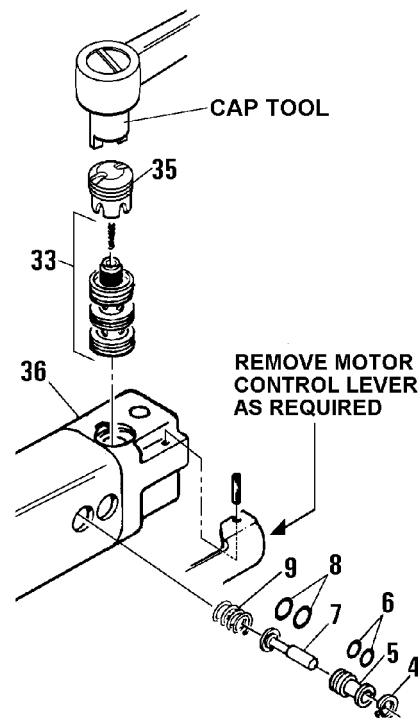

HANSEN PLUG

When removing/connecting the Hansen plug, hold the air motor inlet fitting with one wrench and tighten the Hansen plug with another. If this is not done, you will loosen or over-tighten the air motor housing, thus affecting performance.

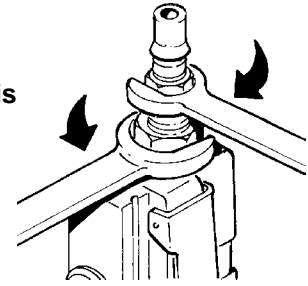

AIR LOGIC AND DIAGRAM

SEQUENCE OF OPERATION

1. Tool at Rest - Air flows through the pilot valve, throttle valve and stops at the air valve. Air also flows to the 3-way valve.
2. Motor control lever is depressed, initiating the tensioning portion of the cycle. Air flows through the pilot valve, throttle valve (used to control strap tension) and the air valve to the rotor/cylinder section of the air motor, causing the air motor to turn. The motor runs until it stalls when strap tension has been reached. Air also flows to and stops at the 3-way valve.
3. The weld handle is pulled back, initiating the welding cycle. Air is directed to the throttle valve (opening it fully allowing full air motor performance) flows through the pilot valve and the air valve to the rotor/cylinder section of the air motor. Additionally, the act of pulling the weld handle back mechanically disconnects the motor from the tensioning mechanism so the air motor starts running again. Air flows through the 3-way valve, the flow control and enters the volume chamber. When sufficient pressure has built up in the volume chamber the pilot valve will actuate and shut off the air flow to the air valve and the rotor/cylinder. The air motor then stops.
4. The motor lever and weld handle are released and the tool returns to the "at rest" configuration, with air being routed through the pilot valve, throttle valve and stopping at the air valve.

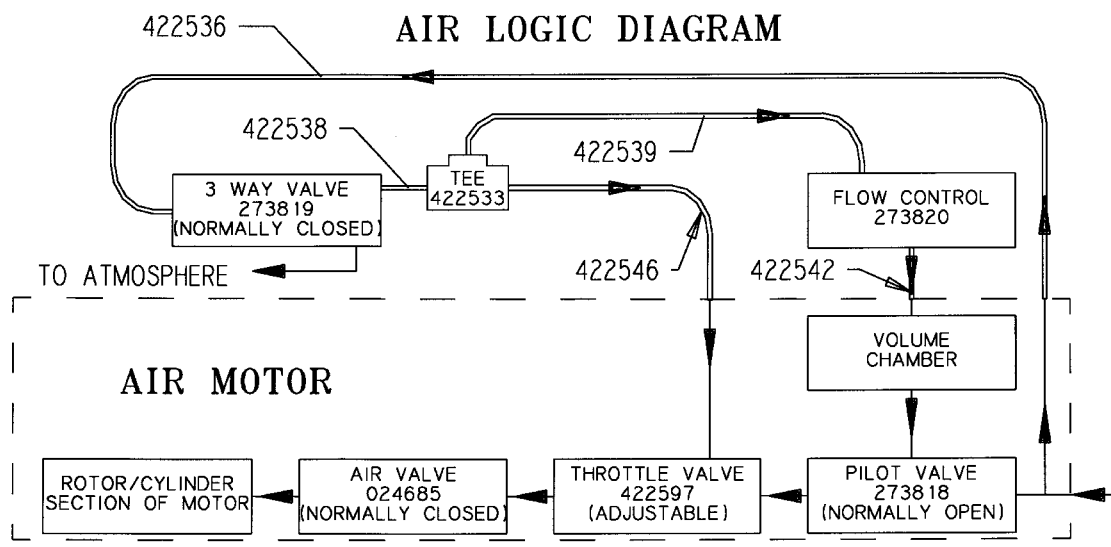

PARTS LIST, AIR MOTORS: IR95R17V (422525) & 95R17V (423900)

<u>KEY</u>	<u>QTY.</u>	<u>422525</u> <u>PART#</u>	<u>423900</u> <u>PART#</u>	<u>DESCRIPTION</u>
1	1	020704	020704	Quick disconnect plug
2	1	422501	024631	Filter assembly
3	2	<u>273822</u>	<u>273822</u>	<u>Fitting</u>
4	1	306838	306838	Retaining ring
5	1	422502	306831	Valve sleeve
6	2	020699	020699	O-ring
7	1	422503	306832	Valve stem
8	5	094295	094295	O-ring
9	1	422521	024661	Spring
10	1	<u>004658</u>	<u>004658</u>	<u>Roll pin 1/8 x 13/16</u>
11	1	422595	422595	Motor housing
13	1	<u>024633</u>	<u>024633</u>	<u>Ball bearing</u>
14	1	<u>422505</u>	<u>023515</u>	<u>Back end plate</u>
15	1	422506	023517	Cylinder
16	1	422507	023510	Align pin
17	5	<u>422508</u>	<u>024651</u>	<u>Vane</u>
18	1	422524	423423	Rotor
19	1	-	024602	Spacer
20	1	<u>422510</u>	<u>090074</u>	<u>Front end plate</u>
21	2	023481	023481	Ball bearing
22	1	023552	-	Ball bearing
23	3	<u>422526</u>	<u>024605</u>	<u>Idler assembly</u>
24	1	422527	090081	Cage (cage assembly)
25	3	<u>422528</u>	-	<u>Pin</u>
26	1	422514	-	Retainer
27	1	422515	024608	Ring gear
28	1	023551	023551	Seal
29	1	023556	023556	Pin
30	1	422516	090078	Gear housing
31	1	422594	422594	Motor cover
32	3	012298	012298	SHCS, 8-32 x 5/8
33	1	273818	273818	Pilot valve
34	1	<u>023446</u>	<u>023446</u>	<u>O-ring</u>
35	1	273845	273845	Valve cap
36	1	422529	422529	Valve housing assy
37	2	274438	274438	Screw
38	1	422593	422593	Motor control lever
39	1	422542	273821	Tubing, 6-5/8" Lg
40	1	422520	422520	Spacer
41	1	280522	280522	Info tag (Hansen Plug)
42	1	422598	422598	Throttle valve cap
43	1	422597	422597	Throttle valve
44	1	422596	422596	Spring
45	1	274442	274442	Fitting
46	1	422532	422532	Spring
47	1	422535	422535	Adjustment screw
48	1	422536	273821	Tubing, 9" Length
49	1	422546	273821	Tubing, 8" Length
50	1	435824	435824	Information sign
51	2	-	090004	Belleville washer
52	1	-	423151	Spacer
53	1	433395	433395	Information Tag (Air Pressure)

These air motors can be identified by inspecting the part number shown on the underside of Key 11 (Mtr Housing).

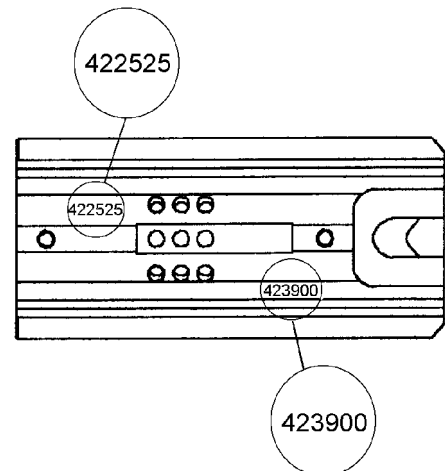

- ! When ordering parts, please show Air Motor number and description.
- ! Standard hardware parts may be obtained from any local hardware supply.
- ! Wearing parts are usually limited to those underlined and should be stocked.

- NOTES: 1. Idler assemblies (23) and vanes (17) must soak in air-line oil over night before assembling air motor. Idler assemblies and bearings except (13), are to be lubricated with Non-Fluid Oil #K-55 or equivalent.
2. Belleville washers (51) must be installed back to back for maximum stacked length.

- * Secure with Loctite #242 or equivalent.
 ** Secure with Loctite #222 or equivalent.
 *** Secure with Loctite #569 or equivalent.

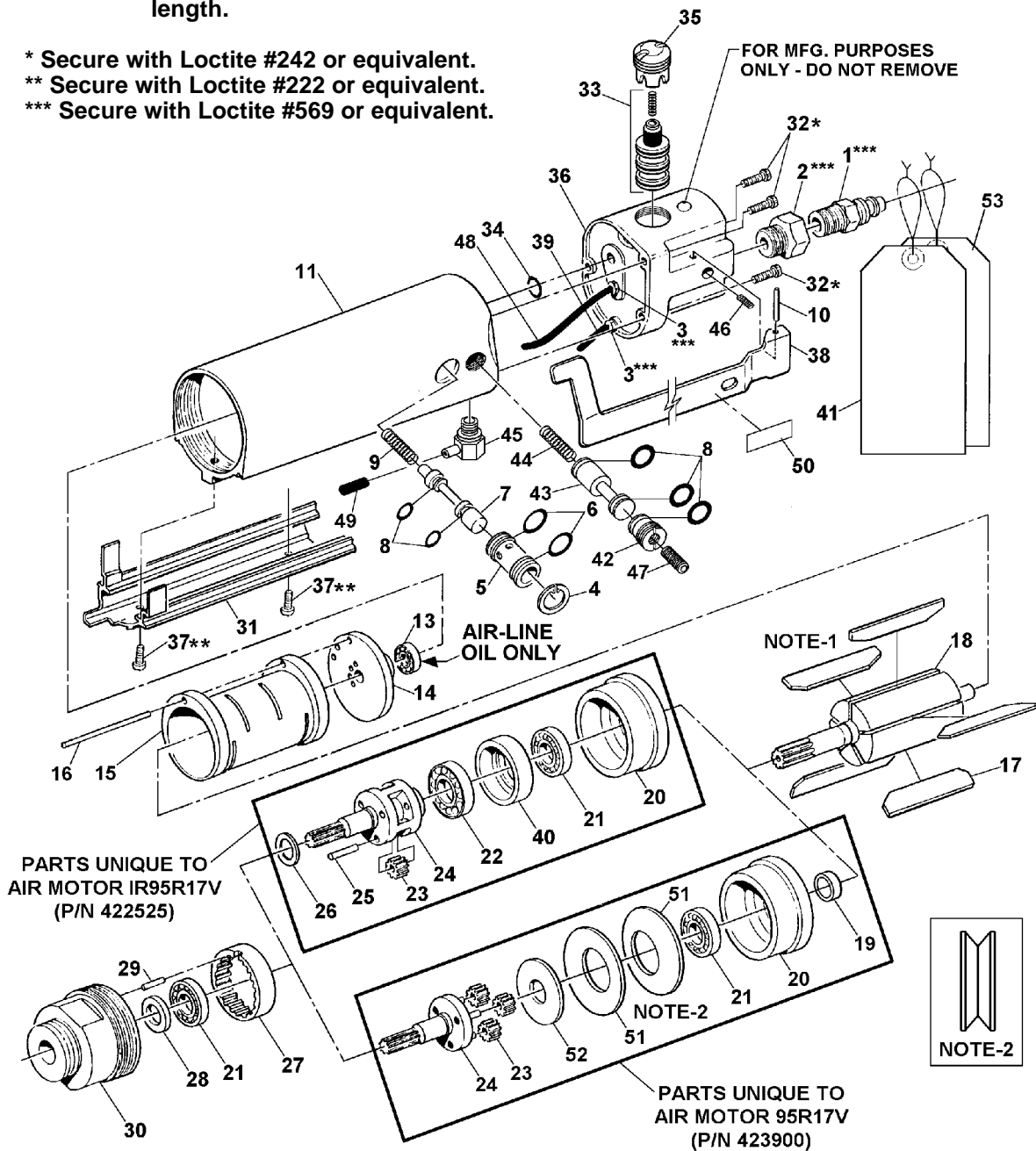

WARNING

The pilot valve (Key 33) must only be serviced by an authorized Signode Service Facility or a maintenance person trained by Signode. NEVER remove the pilot valve when air is connected to the tool. Removing a pilot valve with air to the tool will cause the valve to violently release from the tool. All parts must be periodically inspected and replaced if worn or broken, Failure to do this can affect a product's operation and can result in severe personal injury. Failure to observe the above could result in severe personal injury.

PARTS LIST, TOOL

KEY	QTY.	PART #	DESCRIPTION	KEY	QTY.	PART #	DESCRIPTION
4	3	423370	Screw	61	1	422586	Knob
5	1	273881	End cap	64	1	<u>273815</u>	<u>Bushing</u>
6	1	023096	O-ring	65	1	<u>008751</u>	<u>Needle bearing,</u> <u>Torrington #M-781</u>
7	1	023097	Bearing, Faf. #9101K	66	1	<u>273823</u>	<u>Pressure Eccentric</u>
8	1	023082	O-ring	68	1	<u>007631</u>	<u>Roll pin, 1/8 X 5/8</u>
9	1	023014	Spacer	69	1	023446	O-ring
10	1	014567	Gear (16)	70	1	286392	Warning sign
	1	023002	Gear (19)	71	1	433420	Nameplate, VXT2-16
11	1	008734	Bearing, Fafnir B-542		1	433421	Nameplate, VXT2-19
12	1	008552	Oil seal	72	1	423425	Gear housing
14	1	306842	Handle	73	1	023963	Brush, not shown
15	2	023093	Key, Woodruff	75	2	016342	SHCS, 1/4-20 x 1 1/2
16	1	422581	Tensioner foot	76	4	009041	SHCS, 1/4-20 x 3/4
17	1	<u>424573</u>	<u>Gripper plug</u>	78	1	<u>422570</u>	<u>Lower gripper</u>
18	1	422555	Gripper guide	79	1	273824	Needle bearing
19	1	306210	FHSCS, #6-32xcl	80	2	<u>273825</u>	<u>Needle bearing</u>
20	1	008624	Roll pin, 1/8 x 1/4	81	1	273828	Shim
21	1	422551	Feedwheel shaft	82	1	422571	Disk
22	1	<u>422578</u>	<u>Feedwheel</u>	84	1	045203	Compression spring, LEE #LC-020 A-5
23	1	274409	Spring torsion	86	1	273834	Spacer
24	1	422582	Weld housing	87	1	306545	Slotted screw, 4-40 x 3/16
25	1	274068	Support pin	88	2	306847	Adjustment screw
26	1	422558	Eccentric shaft	92	1	008746	SHCS, 1/4-20 x 3/8
27	1	273859	Gear idler	94	1	286373	3-Icon info. sign
27A	1	422913	Gear/Bearing Assy	95	3	422572	Pin
28	1	014566	Spiroid pinion (16)	96	1	422584	Guide Plate
	1	014517	Spiroid pinion (19)	97	2	261833	BHSCS, #10-24x1/4
29	1	014530	Needle bearing, Torrington #B-47	98	1	422533	Tee
30	1	306856	Dowel pin	99	1	422538	Tubing, 5/8" length
31	1	014527	Bearing, Fafnir #7202W	100	1	422539	Tubing, 1/2" length
32	1	014556	Washer	101	1	422831	Pin
33	2	014549	Brake spring	103	2	422577	Inner guide
34	1	306839	Brake	104	3	423426	SHCS
35	1	422562	Spacer sleeve	105	1	422576	Guide spacer
36	1	014542	Clutch spring	106	1	422587	3/32 Hex wrench (not shown)
37	1	306865	Clutch				
38	1	014529	Needle bearing, Torrington #B-68				
39	1	422564	Drive gear				
39A	1	422565	Drive gear assembly				
40	1	014528	Bearing				
41	1	422566	Motor mount				
42	1	422301	Locking ring				
43	1	<u>273883</u>	<u>Compression plate</u>				
44	1	<u>273858</u>	<u>Contact stem</u>				
45	1	273812	Die spring				
46	1	<u>422567</u>	<u>Cutter blade</u>				
47	1	306869	Pin				
48	1	<u>422108</u>	<u>Slider link</u>				
49	1	273850	Lift tab				
50	1	<u>273842</u>	<u>Pin</u>				
51	1	422110	Pin, pivot				
52	1	<u>422109</u>	<u>Upper gripper</u>				
53	1	273820	Flow control				
54	2	<u>274442</u>	<u>Fitting</u>				
56	1	273819	3-way valve				
58	1	273827	Oil seal				
60	1	422549	Weld handle				

! When ordering parts, please show tool model, part number and description.

! Standard hardware parts may be obtained from any local hardware supply.

! Wearing parts are usually limited to those underlined and should be stocked.

⚠ WARNING

Inspect all parts daily and replace them if they are worn or broken. Failure to do this can affect a product's operation and could result in serious personal injury.

NOTE: Install pivot pin (Key 51) through slider link (Key 48) flush to right-hand side of upper gripper (Key 52).

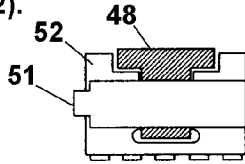

NOTE: Install pin (Key 30) into motor mount (Key 41) as shown. The pin should be flush with the outer edge of the motor mount casting.

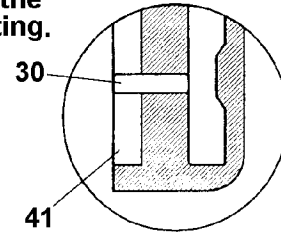

KEY 42
Install to 450-550 in-lbs. (50-60 Nm) of torque.

AIR MOTOR
Secure mounting threads with Loctite #242.

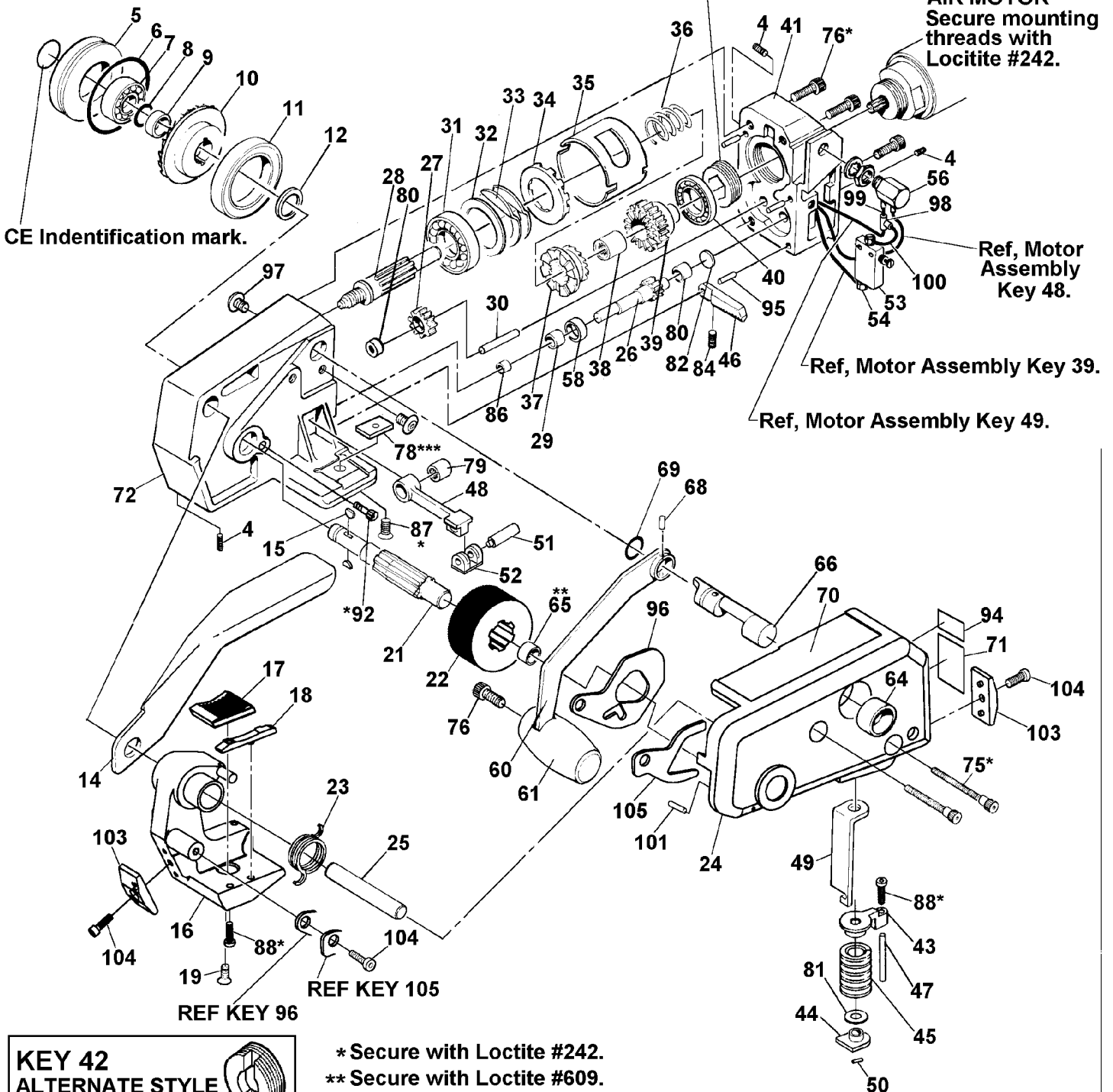

- * Secure with Loctite #242.
- ** Secure with Loctite #609.
- *** Secure with Loctite #380 Black Max.

TROUBLESHOOTING

The following items are the most common types of tool malfunctions. For symptoms or remedies not shown, contact your Signode service representative for additional information and details. The following tool conditions are shown in this manual:

AIR SUPPLY

- #1 - The air motor is frozen.
- #2 - A leaking or sticking air valve.
- #3 - The tool runs sluggishly.

TENSIONING

- #4 - Feedwheel milling on strap and/or strap breaking.
- #5 - The top strap is being properly tensioned but the tool does not hold the bottom strap.
- #6 - The tool stops tensioning before maximum tension is reached (air motor continues to run).

WELDING

- #7 - A poor weld identified by an incomplete area of weld.
- #8 - Incomplete or no weld.
- #9 - Strap is over welded.
- #10 - Motor shut-off is sluggish.
- #11 - Strap weld time is erratic.
- #12 - Weld time is too long.

CUT-OFF ACTION

- #13 - The cut-off has become difficult.
- #14 - Weld strap is misaligned.

#1 CONDITION: The air motor is frozen.	
CAUSE	REMEDY
The motor is dry, hindering it from providing maximum performance.	Add several drops of oil into the motor through the air inlet. Hook the tool up to air, depress and hold the operating lever while gently tapping the motor with a rubber mallet. Repeat this procedure several times if necessary.

#2 CONDITION: Air valve leaking or sticking.	
CAUSE	REMEDY
Worn, damaged or dirty O-ring on valve stem.	Clean and lubricate the valve stem assembly and the valve sleeve assembly. Replace the O-ring on the valve stem if necessary.

#3 CONDITION: The tool runs sluggishly.

CAUSE	REMEDY
1. The air filter-regulator-lubricator is malfunctioning or is not properly maintained.	1A. Check the regulator to see that the correct air pressure is getting to the tool. 1B. Check to see the filter unit is clean and functioning properly. 1C. Examine the lubricator to see there is oil in the bowl and that oil is seen dripping from the sight dome as the tool operates. This assures the air motor is being properly lubricated.
2. The tool may run sluggishly due to a clogged or dirty motor filter screen due to a lack of properly filtered air supply.	2. Remove the Hansen plug at the inlet to the air motor and examine the filter screen in the filter assembly and clean it if necessary. See "Special Instructions", page 9, on removing Hansen plug.
3. The tool may run sluggishly due to an improper air motor adjustment or a clogged or dirty vibrator assembly.	3. Refer to Parts Removal and Replacement, Air Motor, for proper motor adjustment. For clogged or dirty weld assembly, see troubleshooting remedy under "Welding".
4. The end plates, pinion teeth on the rotor and the rotor blades are worn, dirty or rusted.	4. Carefully remove the air motor from the tool and disassemble it. If these parts are only dirty, clean, thoroughly oil and reassemble. If they are worn or rusted, replace them.

#4 CONDITION: Feedwheel milling on strap and/or strap breaking.

CAUSE	REMEDY
1. Feedwheel is clogged with dirt or strap residue.	1. Clean teeth on feedwheel with the special brush provided.
2. Worn teeth on the feedwheel.	2. Replace the feedwheel.
3. The bushing in the weld housing has worn because of a lack of lubrication.	3. Replace the bushing.
4. Excessive or improperly set feedwheel to gripper plug clearance.	4. Adjust feedwheel as required, see page 13, Feedwheel to Gripper adjustments.
5. VXT-19 Break-in period performance change.	5. Adjust the air motor as required, see "Strap Tension" on page 7 of this manual.

#5 CONDITION: The top strap is being properly tensioned but the tool does not hold the bottom strap.

CAUSE	REMEDY
1. The gripper plug may be packed with dirt or strap residue preventing the teeth from penetrating the strap.	1. Clean the gripper plug with the special non-metallic tool brush.
2. Worn teeth on the gripper plug.	2. Replace the worn plug. Since the feedwheel and gripper plug are prevented from contacting one another by an inside shoulder on each part, it is not often these parts have to be replaced.
3. VXT-19 Break-in period performance change.	3. Adjust the air motor as required, see "Strap Tension" on page 7 of this manual.

TROUBLESHOOTING, Continued

#6 CONDITION: The tool stops tensioning before maximum tension is reached, but the air motor continues to run.	
CAUSE	REMEDY
This is an indication that the clutch and drive gear teeth are worn through normal use, or the clutch and drive gear teeth are worn due to improper tool usage, i.e., activating the eccentric handle before stall-out occurs during the tensioning cycle. Refer to Operating Instructions for proper tool usage.	These parts must be replaced. See Parts Removal and Replacement Section.

#7 CONDITION: A poor weld identified by an incomplete area of weld.	
CAUSE	REMEDY
The grippers have become clogged with strap residue or the bearings in the weld mechanism are extremely dry. Welding is achieved by a combination of vibration and downward pressure of the upper gripper. Either a restriction of motion or a reduction of downward pressure will cause a poor weld.	Dismantle and clean the weld mechanism by brushing away the strap residue or washing the entire unit in a solvent. When a solvent is used it is imperative the assembly be blown dry to remove all solvent. Check for dry or worn bearings in the slider link and gear housing. Replace or lubricate as required. If the tool has been used extensively, examine the teeth on the upper and lower grippers for wear. Replace if worn. Lubricate the weld mechanism with Mo-Lith #2 grease and reassemble.

#8 CONDITION: Incomplete or no weld.	
CAUSE	REMEDY
<ol style="list-style-type: none"> 1. Improperly set weld time adjustment. 2. Worn teeth on upper or lower gripper. 3. Insufficient air supply pressure. 4. Worn pressure eccentric or bushing in weld housing. 5. Worn slider link. 	<ol style="list-style-type: none"> 1. Adjust weld time as required per instruction in this manual. 2. Replace as required. 3. Remedy as required. 4. Replace as required. 5. Replace as required.

#9 CONDITION: Strap is over welded.	
CAUSE	REMEDY
Improper weld timing adjustment.	Decrease weld timing as needed.

#10 CONDITION: Motor shutoff is sluggish.	
CAUSE	REMEDY
<ol style="list-style-type: none"> 1. Dirty air filter in air logic circuit. 2. Air leakage in the timing circuit. 	<ol style="list-style-type: none"> 1. Replace as required. 2. Check air lines and fittings for leaks.

#11 CONDITION: Strap weld time is erratic.	
CAUSE	REMEDY
Dirty or very dry valve in air motor valve housing.	Add a several drops of airline oil into the air inlet of the tool and cycle several times to lubricate. If the problem persists, review the air motor valve housing maintenance instructions found in this manual.

#12 CONDITION: Weld time is too long.	
CAUSE	REMEDY
Too much oil in the air supply system of the tool.	Purge the tool of all excess oil. See instructions Excess Oil Removal found in this manual.

#13 CONDITION: The cut-off has become difficult.	
CAUSE	REMEDY
1. Strap residue jamming cutter mechanism.	1. Clean parts as required.
2. Adjust cutter as needed.	2. Adjust cutter per instructions in this manual as required.
3. Cutter blade worn or damaged beyond adjustability.	3. Follow cutter blade replacement procedures.
4. Broken or damaged cutter spring.	4. Replace as required.

#14 CONDITION: Welded strap is misaligned.	
CAUSE	REMEDY
The tool is not being operated properly.	Review "Tool Operation" on pages 10 & 11 of this manual for proper operation of tool.

MAINTENANCE

TOOL

1. Always be sure the tensioner foot is free and periodically lubricate the support pin.
2. Clean the teeth on the feedwheel and the gripper plug with the special brush provided, (Part No. 023963).
3. Periodically clean the tool with an air hose.
4. Disassemble, clean and lubricate the welding mechanism.



GEAR HOUSING

Periodically check the gear housing portion of the tool:

1. Remove the end cap (5) from the front of the gear housing by removing the set screw (4) and pulling the end cap off.
2. Check for adequate lubrication and wear of the Spiroid worm (28) and gear (10).

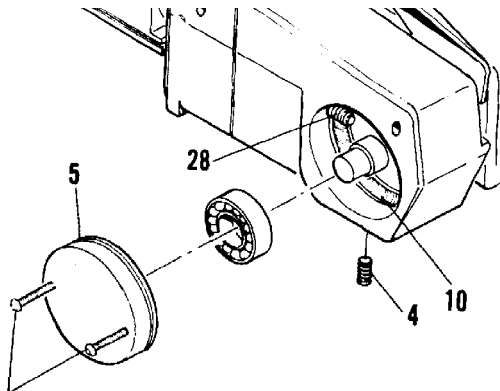

INSERT 2 #10-24 SCREWS, (NOT PROVIDED), INTO END CAP TO ASSIST IN REMOVAL FROM HOUSING.

3. This portion of the tool should be from 20% to 50% full of Non-Fluid Oil K-55.
4. Reinstall the end cap.

EXCESS OIL REMOVAL

If the weld time is too long and seemingly cannot be adjusted the tool may have an excessive amount of oil internally. Purge the tool of the excess oil as follows:

1. Open the flow control fully by turning the adjusting screw fully counterclockwise (approximately 7 turns).
2. Attach the air supply to the supply inlet. With out operating the air motor, pull the weld handle to the full rear position.
3. Once the handle has been pulled back, the weld air valve will shift (air valve shifting can be heard by an audible rush of air). Push the handle back to the forward position once the valve has shifted. Perform this operation a few times.
4. Once again bring the weld handle to the rear position. The timer should begin to shut off the valve automatically. When the valve is shut off almost as soon as the weld handle is pulled to the rear, the excess oil has been purged.
5. Reset the flow control adjustment so that the proper weld time is restored.
6. Refer to page 7 for proper air supply lubrication.

TOOL OPTIONS

OVERHEAD SUSPENSION

To work effectively, your VXT2 tool must be properly installed. This installation includes, in some cases, proper suspension of the tool over the container to be strapped, and the proper placement of a strapping dispenser to provide a continuous easy supply of strapping for the application. The VXT2 can be suspended in various operating positions by using the proper tool hanger and hardware.

Consult the table below for the appropriate configuration for the tool application.

NOTE: Each hanger is supplied with two #10-24x3/4" socket head cap screws (Part No. 008731) for mounting the hanger to the tool.

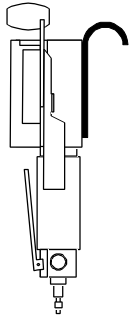
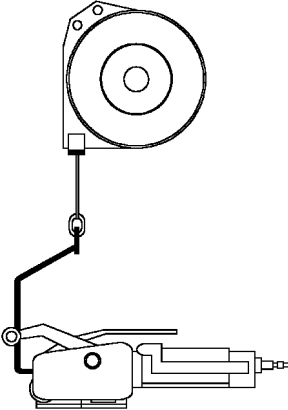
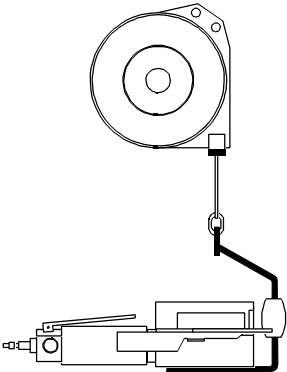
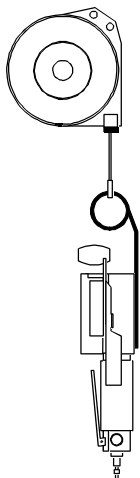
VERTICAL STORAGE	TOP SEALING *	HORIZONTAL SEALING *	VERTICAL SEALING *
			
P/N 306397	P/N 274437	P/N 274437	P/N 274164

* Shown with the recommended Overhead Tool Balancer, Signode Model Number P-306809.

WEAR PLATE, Part No.306857

An optional wear plate can be installed on any VXT2 tool. This option is to protect the base plate from abuse from rough surfaces such as brick and block. The wear plate is secured to the tool using two 10-24x3/8" (Part No. 023099) button head cap screws.

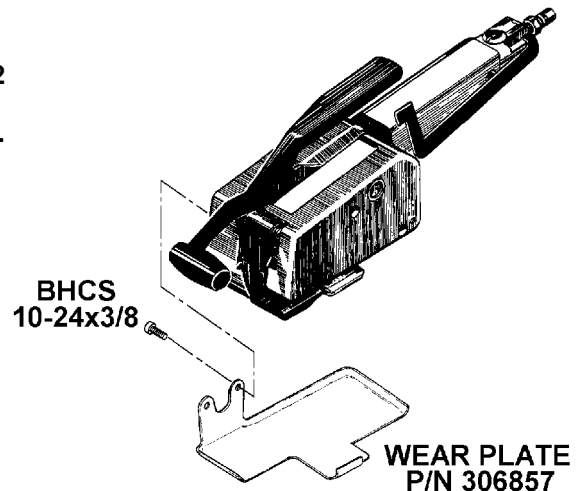

VERTICAL AIR COUPLING, Part No. 422590

This option routes the pneumatic connection to the front of the tool rather than the rear. This option is extremely useful for applications which are close to the floor where the standard pneumatic connection and supply hose could get in the way.

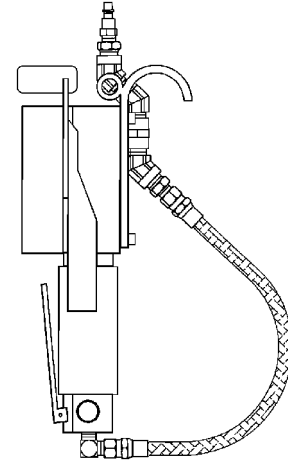

<u>KEY</u>	<u>QTY</u>	<u>PART NO.</u>	<u>DESCRIPTION</u>
1	1	020710	Elbow, 90°
2	1	004154	Hose
3	1	086718	Coupling
4	3	036419	Elbow, 45°
5	1	422588	Mounting plate assy
6	1	036408	Reducer bushing
7	1	020704	Quick disconnect plug
8	4	009397	Socket head cap screw

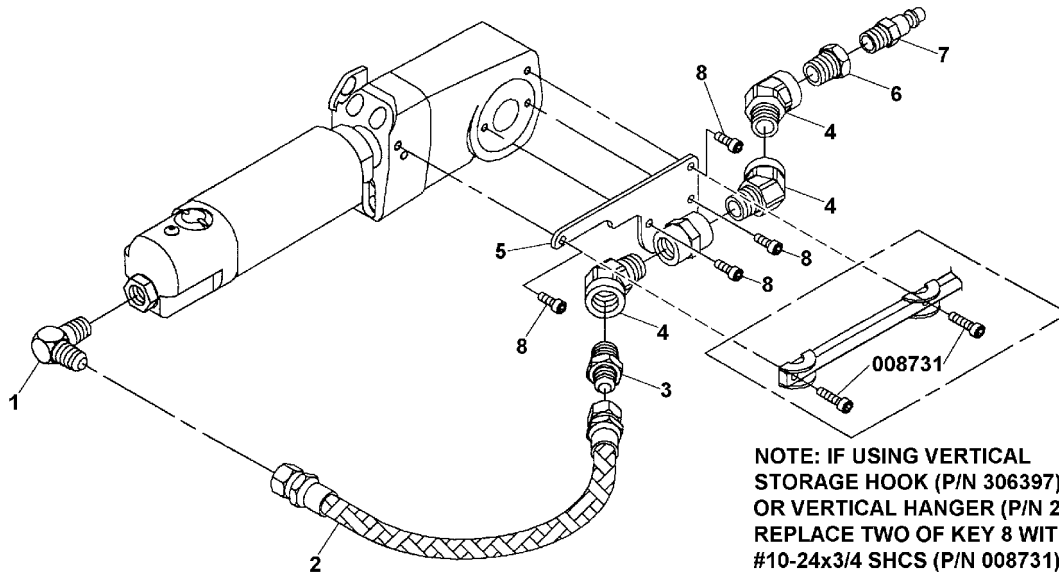

NOTE: IF USING VERTICAL STORAGE HOOK (P/N 306397) OR VERTICAL HANGER (P/N 274164) REPLACE TWO OF KEY 8 WITH TWO #10-24x3/4 SHCS (P/N 008731).



EU Declaration of Conformity
The Supply of Machinery (safety) Regulations
1992 (S.I. 1992/3073)

It is hereby declared that the undermentioned machinery has been designed and constructed to comply with the health and safety requirements defined in EC Directive 89/392/EEC

Machine Supplier: Signode, Division of ITW Ltd.
Queensway, Fforestfach
Swansea SA5 4ED

Machine Description: VXT2 Series

Machine Type: Pneumatic Combination Hand Strapping tool.

Provisions with which machine complies:

89/392/EEC, 91/368/EEC

Harmonized EuroNorms with which machine complies:

EN 292:1, EN 292:2, EN 294, EN 349

Technical Standards with which machine complies:

NA

Signature: 
(Peter Oseland)

Date: 1 Sept 2000

SIGNODE NEW TOOL WARRANTY

Signode Engineered Products Warrants that a new Signode strapping tool will operate per functional specifications for a period of sixty (60) days after the date of shipment to the owner's place of business. Normal wearing parts, as outlined in the Operation, Parts & Safety manual, are covered by a thirty (30) day warranty unless, in Signode's judgement, these parts have been subjected to abnormal or extreme usage. Signode's sole liability hereunder will be to repair or replace, without charge, F.O.B. Signode's Glenview, Illinois plant, any tool which proves to not operate per functional specifications within the stated period. Signode reserves the right to replace any tool which proves not to operate per functional specifications with a new or like-new tool of the same model if in Signode's judgement such replacement is appropriate. Any new replacement tool provided to an owner will carry a full sixty (60) day warranty. Any warranty repaired tool or like-new replacement tool will carry a warranty for the balance of the time remaining on the initial sixty (60) day warranty. This warranty will be extended to compensate for the time the tool is in Signode's possession for warranty repairs.

This warranty is void as to any tool which has been: (I) subjected to mis-use, misapplication, accident, damage, or repaired with other than genuine Signode replacement parts, (II) improperly maintained, or adjusted, or damaged in transit or handling; (III) used with improperly filtered, unlubricated air or improper strapping material, (IV) in Signode's opinion, altered or repaired in a way that affects or detracts from the performance of the tool.

SIGNODE MAKES NO WARRANTY, EXPRESSED OR IMPLIED, RELATING TO MERCHANTABILITY, FITNESS OR OTHERWISE EXCEPT AS STATED ABOVE AND SIGNODE'S LIABILITY AS ASSUMED ABOVE IS IN LIEU OF ALL OTHERS ARISING OUT OF OR IN CONNECTION WITH THE USE AND PERFORMANCE OF THE TOOL. IT IS EXPRESSLY UNDERSTOOD THAT SIGNODE SHALL IN NO EVENT BE LIABLE FOR ANY INDIRECT OR CONSEQUENTIAL DAMAGES INCLUDING, BUT NOT LIMITED TO, DAMAGES WHICH MAY ARISE FROM LOSS OF ANTICIPATED PROFITS OR PRODUCTION, SPOILAGE OF MATERIALS, INCREASED COSTS OF OPERATION OR OTHERWISE.

Considerable effort has been made to ensure that this product conforms to our high quality standards. However, should you experience any difficulties, please contact your Sales Representative providing samples and the manufacturing code specified on the tool.

Thank you for your help.

SIGNODE ENGINEERED PRODUCTS
Hand Tool Division
3620 W. Lake Avenue, Glenview, Illinois 60025

PART #	DESCRIPTION	AREA OF USE
LUBRICANTS		
177029	BROWN K-55 GREASE	CLUTCH DRIVES, INTERNAL GEARS, GEAR SETS
422792	WHITE LUBRIPLATE GR-132 GREASE	PNEUMATIC PARTS, AIR CYLINDERS, AIR VALVES, O-RINGS
422793	BLACK LUBRIPLATE 3000W GREASE	MOVING INTERNAL PARTS, JAWS, LINKS
432322	EP ACCROLUBE GREASE	HIGH FRICTION CONTACT PARTS
008556	LS-1236 AIR LINE OIL	AIR MOTORS, AIR VALVES
ADHESIVES		
422794	LOCTITE #222, PURPLE	LOW STRENGTH, SCREWS 1/4" (6MM) OR SMALLER SIZES
422795	LOCTITE #242, BLUE	MEDIUM STRENGTH, SCREWS 5/16" (8MM) OR LARGER SIZES
422796	LOCTITE #271, RED	HIGH STRENGTH, SEMI-PERMANENT SCREW APPLICATION
422797	LOCTITE #609, GREEN	PERMANENT, CURVED SURFACE PART CONTACT
274111	LOCTITE #380, BLACK MAX	PERMANENT, FLAT SURFACE PART CONTACT
CLEANING BRUSHES		
023963	SMALL BRUSH	FEEDWHEEL & GRIPPER TEETH
269589	LARGE BRUSH	FEEDWHEEL & GRIPPER TEETH