

OPERATION, PARTS AND SAFETY MANUAL



SIGNODE®

SPC-100/114

PNEUMATIC COMBINATION STRAPPING TOOL

**IMPORTANT!
DO NOT DESTROY**

**It is the customer's responsibility to
have all operators and servicemen
read and understand this manual.**

Contact your local Signode representative
for additional copies of this manual.

READ ALL INSTRUCTIONS BEFORE OPERATING THIS SIGNODE PRODUCT

SIGNODE • 3620 WEST LAKE AVENUE • GLENVIEW, ILLINOIS 60025 U.S.A.

SAFETY INSTRUCTIONS

READ THESE INSTRUCTIONS CAREFULLY.

FAILURE TO FOLLOW THESE INSTRUCTIONS CAN RESULT IN SEVERE PERSONAL INJURY.

GENERAL SAFETY CONSIDERATIONS

1. STRAP BREAKAGE HAZARD.

Improper operation of the tool or sharp corners on the load can result in strap breakage during tensioning, which could result in the following:

- A sudden loss of balance causing you to fall.
- Both tool and strap flying violently towards your face.



Failure to place the strap properly around the load or an unstable or shifted load could result in a sudden loss of strap tension during tensioning. This could result in a sudden loss of balance causing you to fall.

Read the tool's operating instructions. If the load corners are sharp use edge protectors. Place the strap correctly around a properly positioned load.

- Positioning yourself in-line with the strap, during tensioning and sealing, can result in severe personal injury from flying strap or tool. When tensioning or sealing, position yourself to one side of the strap and keep all bystanders away.

2. TRAINING.

This tool must not be used by persons not properly trained in its use. Be certain that you receive proper training from your employer. If you have any questions contact your Signode Representative.

3. EYE INJURY HAZARD.

Failure to wear safety glasses with side shields can result in severe eye injury or blindness. Always wear safety glasses with side shields which conform to ANSI Standard Z87.1 or EN 166.



4. FALL HAZARD.

Maintaining improper footing and/or balance when operating the tool can cause you to fall. Do not use the tool when you are in an awkward position.

5. CUT HAZARD.

Handling strap or sharp parts could result in cut hands or fingers. Wear protective gloves.



6. TOOL CARE.

Take good care of the tool. Inspect and clean it daily, lubricate it weekly and adjust when necessary. Replace any worn or broken parts.

7. WORK AREA.

Keep work areas uncluttered and well lighted.

8. OPERATING SEQUENCE.

Use the correct Signode products for your application. If you need help contact your Signode Representative. Before using this sealless tool, read the Operation and Safety Instructions contained in this manual.

9. JOINT FORMATION

Sealless joints are formed when overlapping straps are punched simultaneously creating interlocking keys. However, the integrity of the joint is obtained when the keys punched in the upper strap move in relation to the keys on the bottom strap, allowing the straps to interlock. The movement necessary to create the interlock comes from the strap tension release where the top strap moves one direction and the bottom strap moves in the other direction. Therefore, never attempt to make a sealless joint without having the straps under tension - the joint may come apart easily.

This tool is a punch type sealer. A properly formed joint will appear as shown in the illustration. If the joint does not appear as shown, then the operator must proceed as follows:

- A. Ensure that the tool's operating instructions are being followed before applying another strap.
- B. Ensure that tension has been applied to the straps before the sealer lever is activated. Tension is necessary to ensure that the keys fully interlock.
- C. After confirming the above cut the strap off and apply another.

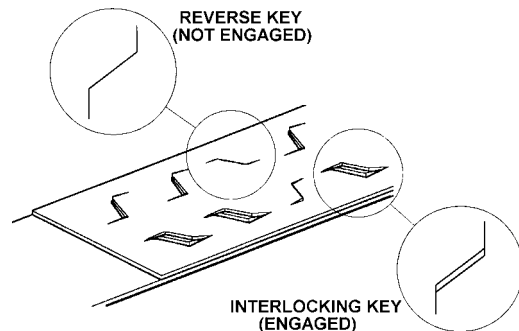

If the joint still does not appear as shown, then inspect the tool for worn and/or damaged parts. Replace tool parts as needed. **NEVER HANDLE OR SHIP ANY LOAD WITH IMPROPERLY FORMED JOINTS.** Misformed joints may not secure the load and could cause serious injury.

Always tuck the strap end back into the dispenser when not in use.

10. CUTTING TENSIONED STRAP

Using claw hammers, crowbars, chisels, axes or similar tools can cause tensioned strap to fly apart with hazardous force. Use only cutters designed for cutting strap. Read the instructions in the cutter's manual for proper procedure in cutting strap. Before using any Signode product read its Operation and Safety Manual.

Safety instructions in Spanish are available from your Signode Sales Representative.

Su vendedor Signode le puede proporcionar los instructivos de seguridad en español.

TABLE OF CONTENTS

	Page
General Safety Instructions	2
Introduction	4
Specifications	5
Major Components	5
Pneumatic Information	6
Operating Instructions	9
Strap Joint Formation & Appearance	12
Part Replacement & Adjustments	12
Parts List	14
Troubleshooting	28
Changing Strap Size	30
Optional Tool Hangers	31
Declaration Of Conformity	35

SPC-100, Part No. 424050
SPC-114, Part No. 423125
SPC-100 Kit, Part No. 423100

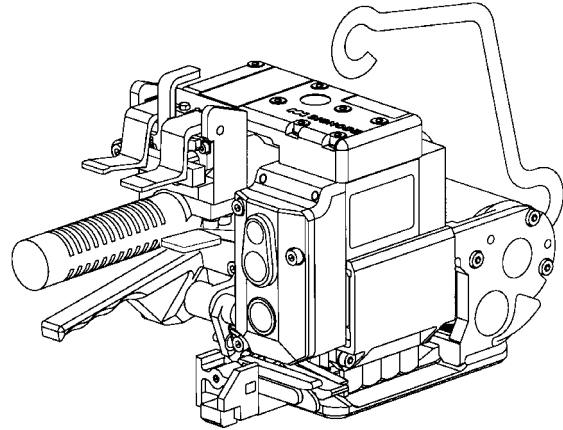

INTRODUCTION

The SPC is a pneumatically operated hand tool intended for use only with Signode strapping. The tool is easy to load, tension and seal.

Once the strap has been placed around the package, the operator puts both layers of strap into the tool, lowers the feed wheel, removes any strap slack and tensions the strap. The keyed sealless joint is then created and the strap is cut free of the supply.

This manual provides the information necessary for the operation of the SPC hand tool and lists all of the parts in the event maintenance is needed. Therefore, it is valuable and should be saved.

Extra care should be taken in performing maintenance on the SPC since fasteners and other small components used on this tool are a combination of SAE and metric sizes.

WARNING

This tool was designed and tested using Signode strap. Using non-Signode strap may adversely affect the tool's tensioning capability and the strength of the joint

SPECIFICATIONS

Operating air pressure: 80-90 PSI (5.5-6.2 BARS)

Physical Dimensions (w/o hanger): 14 1/4" L x 6 1/4" W x 8 1/4" H (362mm x 159mm x 210mm)

Weight: 37 pounds (164N) w/ tool hanger.

MODEL	STRAP			STRAP TENSION @ 90 PSI
	TYPE	WIDTH	THICKNESS	
SPC-100	MAGNUS	1" (25mm)	.025 to .031" (0.64 - 0.78mm)	3000 LBS (13320N)
SPC-114		1-1/4" (32mm)		

MAJOR COMPONENTS

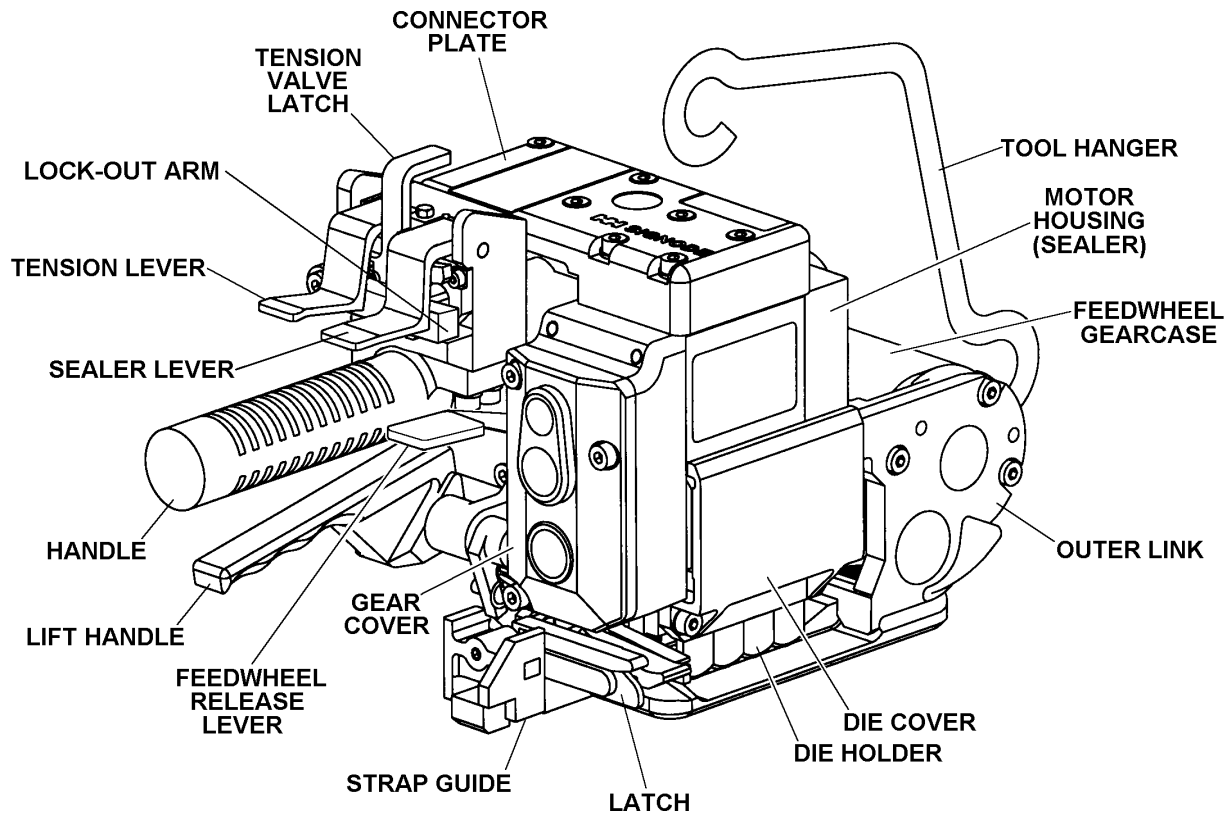

PNEUMATIC INFORMATION

AIR LINE PIPING INSTALLATION

If compressor has a good dryer unit, use black pickled pipe. When a dryer unit is not installed, use galvanized or copper pipe.

To perform reliably, a pneumatic tool requires a continuous source of clean, water-free air at adequate pressure.



A filter-regulator-lubricator unit (Signode Part No. 173111) must be installed as close to the air tool as possible, preferably within 10 feet. It should be placed in a convenient location where it can easily be drained, adjusted, and filled with oil. The air hose must have at least a 3/8" I.D. A quick-connect press-on socket is installed on the stress spring end of the hose for convenient hookup to the air tool.

Filter and lubricator bowls are made of polycarbonate material. Do not install where bowls may be exposed to materials incompatible with polycarbonate. Certain oils, solvents, and chemicals or their fumes can weaken these bowls and possibly cause them to burst. Clean only with warm water.

A cut-off valve placed ahead of the filter will be useful when cleaning the filter or replenishing the lubricator.

MOISTURE

Moisture is always present in air lines due to condensation within the lines as the air cools. Steps must be taken to remove this moisture and to keep it from the air tool. This is because water tends to wash away lubricants and cause corrosion, sticking and failure of internal parts.

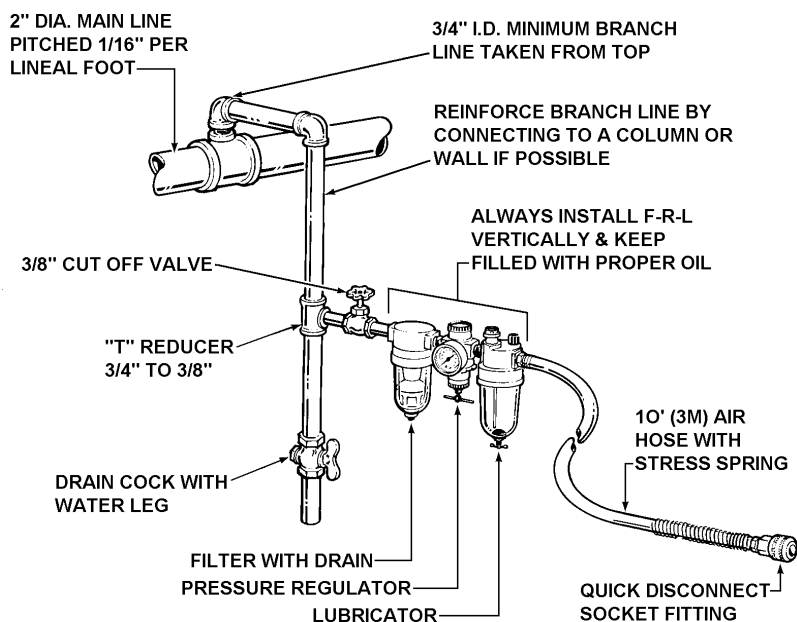

The main line should be pitched so the far end terminates in a water leg. Branch lines are taken from the top of the main, never off the bottom. Every branch should have a water leg at its lowest point, with a drain cock which is drained daily.

If these precautions are taken and water is still present, an after cooler and a moisture separator are required between the compressor and the air receiver tank. A large air line separator can be installed in the air tool line, but precautions must be taken to insure that it will be drained daily, before the air tool is operated.

Water in air lines is a constant threat to the proper operation of air tools. Even near freezing operating conditions, a good refrigerant type dryer is essential. A good dryer will remove 95% or more of water right at the compressor. The remaining moisture is removed at the water leg in the piping system or in the filter, Signode Part No. 173111. Additional information is available in the Signode publication, "Air Supply Manual" Signode Part No. 186038. If you have any questions, contact your local Signode Representative.

LUBRICATION

The air motor must be properly lubricated. This is achieved by keeping the air line lubricator filled with oil and correctly adjusted. Without proper lubrication, the motor will become sticky and the tool will give low and erratic tension and be difficult to release from the strap.

Install the lubricator as close to the air tool as possible. The arrow on the lubricator's top surface must point in the direction of air flow.

For proper operation, oil must drop through the lubricator sight glass at a rate of 4 to 10 drops per minute. This rate is to be checked while the air tool is running free. Only 20% of this oil is actually delivered to the tool. The remaining oil drops back into the oil reservoir. The unit is factory set and should require no adjustment. If an adjustment is required, the adjusting screw on top of the lubricator may be turned as marked to reduce or increase the flow of oil.

The correct grade of oil must be used in the lubricator; too heavy an oil will not provide sufficient lubrication and will cause sticking and sluggish operation of the air tool.

Recommended oils are any good grade of rust and oxidation inhibiting oil with a viscosity of 80-120 S.U.S. at 100 degrees Fahrenheit. (0.15 to 0.25 cm² /sec. at 38 degrees Celsius), such as:

Non Fluid Oil Co., grade #LS-1236
Signode oil - Part No. 008556

If necessary, use SAE #5 or SAE #10, non-detergent, cut 1:1 with kerosene. Some oils contain anti-wear additives which may disable the air motor. Be certain to use recommended oil.

Several drops of lubricator oil added to the inlet of the air motor or into the air line each day will help insure good operation. A noticeable reduction of air motor performance can usually be corrected by squirting a few drops of oil into the air line.

COLD WEATHER OPERATION

If a tool does not operate satisfactorily in freezing temperatures, certain steps can correct the problem. The following steps can be taken to improve cold weather operation of the tool:

- a. An air line dryer adjacent to the compressor.
- b. Use lubricant recommended by Signode. Signode has tested the use of anti-freezes, none work well in air tools; the tool will gum up when anti-freezes are introduced and will not function properly. The best lubricant for freezing weather is the 1 to 1 oil and kerosene combination.
- c. If possible, run the air supply line to a indoor located Filter-Regulator-Lubricator or relocate the F-L-R to a warmer operating area.

AIR CONSUMPTION

Air consumption in cubic feet per minute (cfm) for the SPC can be calculated as follows:

$$\text{cfm} = (a) \times (b) \times (0.37)$$

a = Number of straps applied per minute.

b = Number of seconds air motor is on per strap during tensioning, from start to finish sealing.

0.37 = SPC efficiency ratio.

Example calculation:

Peak strapping load is 4 straps/minute, so a=4. Air motor is on 5 seconds/strap, so b=5. SPC efficiency ratio is 0.30.

$$(a) \times (b) \times (0.37) = 4 \times 5 \times 0.37 = 7.4 \text{ cubic ft/min.}$$

Air pressure is assumed to be 90 psig with the recommended size and length of air hose. Volume of air at room temperature and sea level pressure, or so-called 'free air' conditions. For more detailed information about air supply systems, refer to Signode manual Part No. 186038.

AIR LINE PRECAUTIONS

Too much air pressure can cause internal tool damage. The maximum operating air pressure for this tool is 90 psig.

WARNING

Strap breakage hazard. Strap breakage can result in severe personal injury. Strap can break during tensioning if inlet air pressure to tool exceeds 90 psig. Maximum operating air pressure is 90 psig.

OPERATING INSTRUCTIONS

⚠️ WARNING

Wear safety glasses. Always position yourself to one side of the strap. Make sure all bystanders are clear before proceeding.

1. STRAP LOADING

Make sure the strap being used is the proper size for the tool model being used. Refer to the Specifications section on page 5 of this manual.

Pass the strap over the top of the package then bring the lead end around and up. This will result in creating a TOP STRAP and a BOTTOM STRAP. They will be referred to later in these instructions.

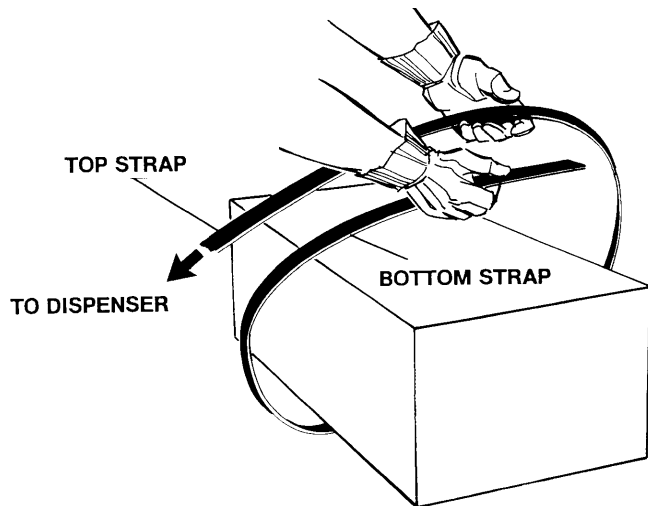

2. LOADING THE BOTTOM STRAP

Squeeze the lifter handle and the stationary handle together to create an opening between the feedwheel and the gripper plug. Grasp the BOTTOM STRAP and insert it sideways into the tool between the feedwheel and the gripper plug. Allow for the lead end of the strap to protrude slightly beyond the tool base. Release the lifter handle.

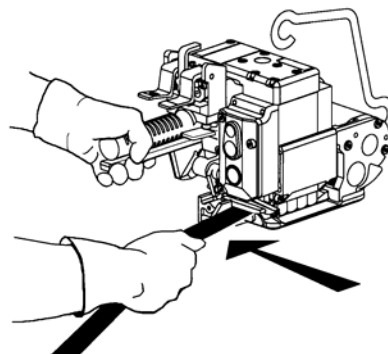

3. LOADING THE TOP STRAP

Grasp the TOP STRAP and insert it sideways into the tool over the Bottom strap between the feedwheel, gripper plug and through the rear strap latch. When both straps are properly inserted, the sealing mechanism will be in line with the strap.

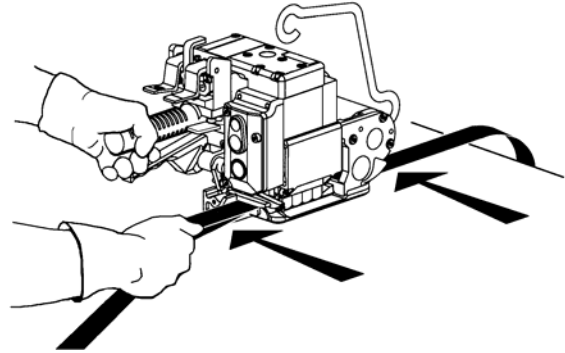

4. REMOVING THE STRAP SLACK

Pull back on the TOP STRAP to eliminate additional slack strap around the package. **NOTE:** Do not lift up on the lift handle or the bottom strap will be released.

Before continuing, make sure the TOP STRAP is still in position, as described earlier. Note that the BOTTOM STRAP will be positioned in the channel on the bottom surface of the tool base. This too, is necessary to maintain strap alignment during tension. Make sure that both straps are also correctly aligned with each other in the tool.

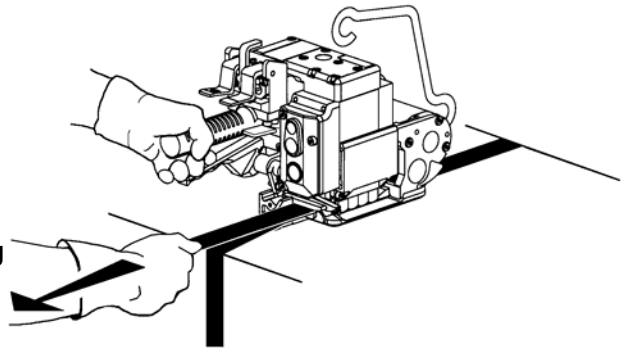

5. TENSIONING THE STRAP

While standing to one side of the strap, press tension lever all the way down until it latches into place.

The tool will tension the strap around the package until the air motor stalls at the adjusted tension setting. Refer to Strap Tension on page 13 of this manual for information on adjusting the strap tension.

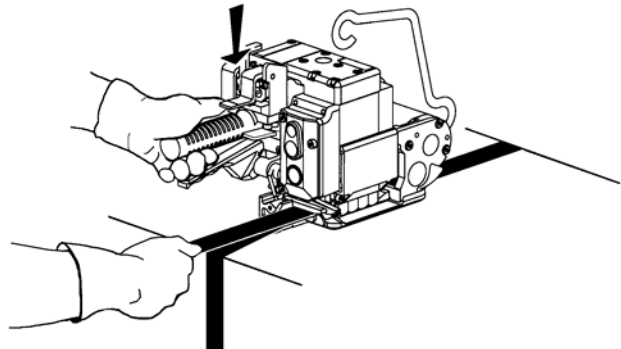

NOTE: If strap alignment on the package is unsatisfactory and it becomes necessary to shut off the tool during the tensioning portion of the cycle press the tension valve latch to the right. Allow the tool a few seconds to back off and raise the feedwheel from the strap by pushing down on the feedwheel release lever. Squeeze the lifter handle or cut the strap from the package if necessary to remove the strap from the tool. Reload and realign the strap.

6. FORMING THE STRAP JOINT

Press down firmly on the sealer lever and release (do not hold the lever down). Air will be then routed to the second air motor enabling the sealer mechanism to punch the strap and cut-off the TOP STRAP. The sealer mechanism will disengage from the strap leaving the cut off end of the strap in the strap latch.

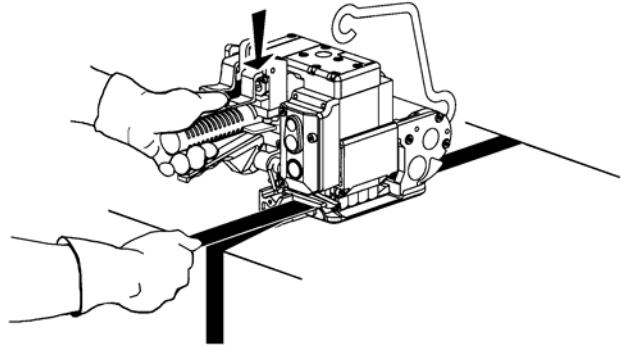

NOTES:

- If the tool does not fully cycle in making the strap joint, it cannot be removed from the strap.
- If the tool does not complete the strap cycle, check for proper operating pressure of 80-90 psi. (5.5-6.2 Bar).
- If the tool stalls using proper air pressure, disconnect air supply and cut strap off of package. Remove the die cover and inspect the tool for broken parts.

6. TOOL REMOVAL & JOINT INSPECTION

Squeeze the lifter handle and the stationary handle together to release the cut off strap end. Swing out the back of the tool to remove the tool from the strap. To make sure the tool has properly formed a joint, closely inspect the strap. Refer to Sealing Operation on the following page for details regarding an acceptably formed joint.

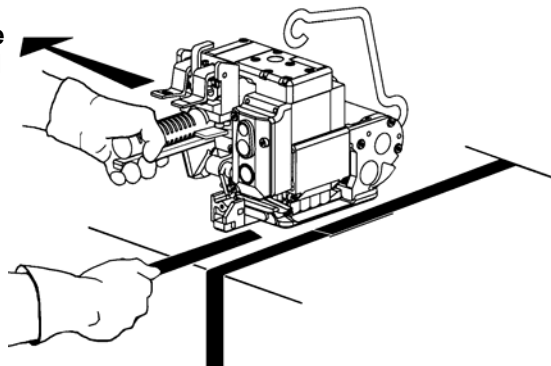

STRAP JOINT APPEARANCE & FORMATION

A properly formed joint will appear as shown in the following illustration.

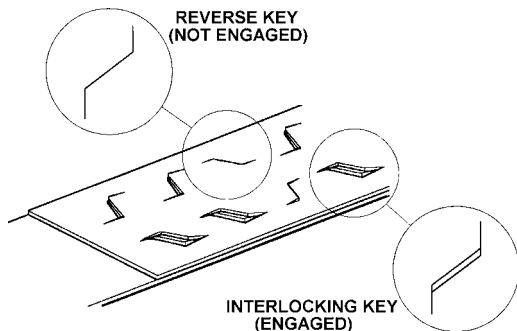

! DANGER

If the joint does not appear as shown, then the operator must proceed as follows:

- Make sure that the tool's operating instructions are being followed before applying another strap.
- Make sure that tension has been applied to the straps before the sealer handle has been actuated. Tension is necessary to ensure that the keys fully interlock.

After confirming the above, cut off the strap and apply another.

If the joint still does not appear as shown, then inspect the tool for worn and/or damaged parts. Replace tool parts as needed.

NEVER HANDLE OR SHIP ANY LOAD WITH IMPROPERLY FORMED JOINTS.

Misformed joints may not secure the load and could cause serious injury.

TOOL ADJUSTMENTS

ADJUSTING STRAP TENSION

(Refer to page 21 for part location and identification.)

! WARNING

1. Wear safety glasses with side shields that conform to ANSI Standard Z87.1 or EN-166.
2. Always wear properly fitting protective gloves when handling strap or sharp parts.
3. Stand to one side of the tool, making sure you have maintained proper balance.

ADJUSTMENT PROCEDURES

1. Properly insert strap into the tool.
2. Do not exceed 90 PSIG.
3. Turn the tool on by pushing the tool's "Tensioning Lever".
4. Using a small screwdriver, turn the needle valve or pressure adjustment screw (Key 311) until the tool stops running.
5. Slowly adjust the needle valve or pressure adjustment screw in 1/2 turn increments until the desired tension has been achieved.

! WARNING

Certain strap sizes could break when increasing tension. Stand to one side of the tool, out of the way of the strap path.

If the strap breaks before the desired tension for your application is achieved, turn the pressure adjustment screw or needle valve 1/2 turn increments until desired tension is reached. If the tension level you have achieved does not properly secure the load in your application, contact your Signode Sale Representative.

TOOL ADJUSTMENTS, Continued

FEEDWHEEL CLEARANCE

Adjust the feedwheel clearance to the clutch plug using the instructions below:

1. Loosen the locknut which secures the set screw.

2. Rotate the set screw clockwise to lift the feedwheel (increase clearance) and counter-clockwise to lower the feedwheel (decrease clearance).

3. The feedwheel to clutch plug clearance should be set to a gap of .001" to .010" (.025mm-.250mm).

4. Retighten the lock nut while holding the set screw in place. Recheck feedwheel to clutch plug clearance.

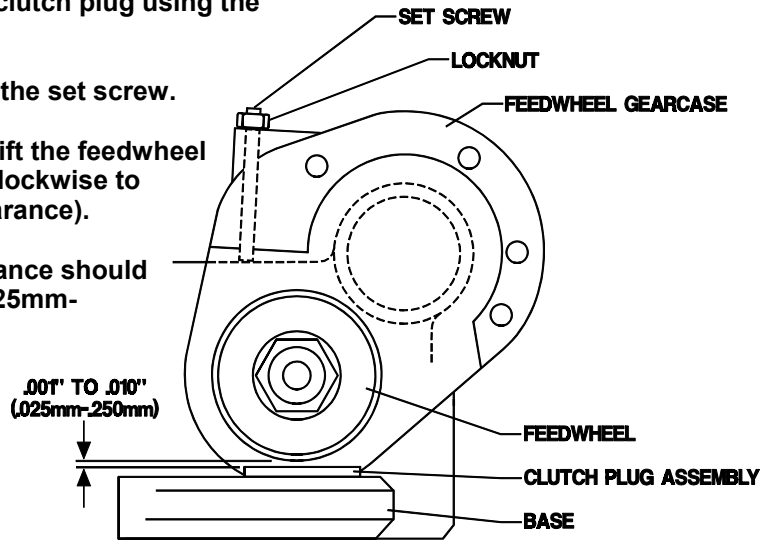

CUTTER ADJUSTMENT

Adjust the cutter clearance using the instructions below:

1. Place the cutter in the down position by first removing the air supply from the tool. Hold the Sealer Lever down and momentarily reconnect the air supply only long enough to move the cutter and die holders down.

2. Loosen the three mounting screws from the bottom of the tool which secure the cutter block.

3. Loosen the flexloc nut which secures the set screw threaded through the strap guide.

4. Turn the set screw clockwise until the cutter block touches the cutter blade. **DO NOT OVER-TIGHTEN THE SET SCREW.**

5. Retighten the 3 mounting screws which secure the cutter block to the tool base.

6. While holding the set screw in place using an allen wrench, tighten the flexloc nut to secure the set screw's position.

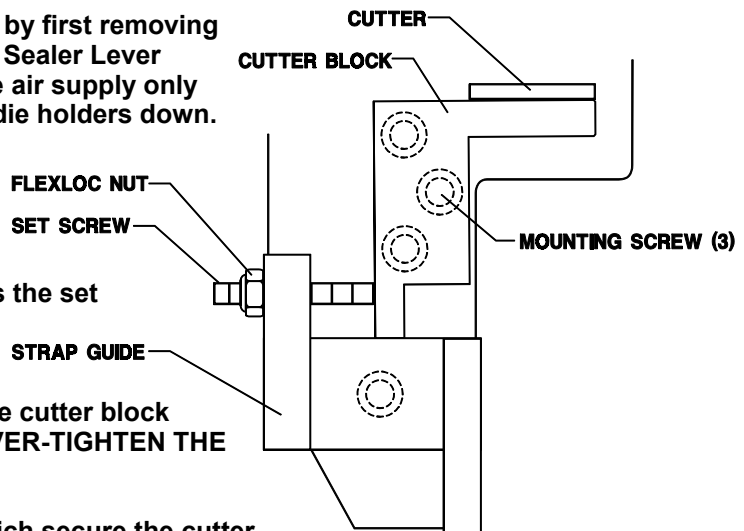

PARTS LIST, BASE ASSEMBLY

<u>KEY</u>	<u>QTY.</u>	<u>PART NO.</u>	<u>DESCRIPTION</u>	
1	1	423043	BASE	
2	1	008754	BALL BEARING KP12	
3	1	423079	RELEASE CAM	
4	1	422645	CIRCLIP #12	
5	1	423050	STRAP GUIDE, FRONT	
6	9	010077	LOCKWASHER M6	
7	7	010037	SHCS M6 X 20	
8	2	280852	LOCKWASHER M4	
9	2	170325	SHCS M4 X 10	
11	2	165437	SHCS M6 X 10	
12	4	423480	FOLLOWER CAM	
13	1	005466	FLEXLOC NUT, M6	
<u>14</u>	<u>1</u>	<u>423075</u>	<u>CUTTER (114)</u>	
	<u>1</u>	<u>424072</u>	<u>CUTTER (100)</u>	
15	1	423068	FOLLOWER SHAFT, CUTTER	
16	3	423082	DIE HOLDER, FORWARD	
<u>17</u>	<u>4</u>	<u>423374</u>	<u>DIE (100)</u>	
	<u>4</u>	<u>423074</u>	<u>DIE (114)</u>	
18	3	423069	FOLLOWER SHAFT, DIE	
19	1	423083	DIE HOLDER, REVERSE	
20	1	423027	DIE COVER	
<u>21</u>	<u>1</u>	<u>423373</u>	<u>PUNCH (100)</u>	
	<u>1</u>	<u>423073</u>	<u>PUNCH (114)</u>	
<u>22</u>	<u>1</u>	<u>423018</u>	<u>CUTTER BLOCK</u>	
<u>23</u>	<u>1</u>	<u>423081</u>	<u>STRAP LATCH, MOVABLE (100)</u>	
	<u>1</u>	<u>423080</u>	<u>STRAP LATCH, MOVABLE (114)</u>	
<u>24</u>	<u>1</u>	<u>423112</u>	<u>STRAP GRIPPER</u>	
25	1	423042	STRAP GUIDE, REAR	
26	1	424982	SHSS M6 X 30	
27	1	270951	PIN, STRAP GUIDE	
28	1	023621	REAR STRAP GUIDE, FIXED	
29	1	423051	GRIPPER LEVER	
30	1	005211	FLEX LOCKNUT, THIN 5/16 X 18	
31	1	422646	CIRCLIP #15	
32	1	423481	BEARING, REAR	
33	1	423090	CAM SHAFT	● When ordering parts, please show tool model, part number and description.
34	1	423035	ROD	
35	2	162568	LOCK WASHER M3	
36	1	423065	STRIPPER #1	● Standard hardware parts may be obtained from any local hardware supply.
37	1	251255	SHCS M3 X 14	
38	4	422831	DOWEL PIN DIA 4 X 10	
39	3	423094	LIFTER #1	
40	1	423095	LIFTER #2	● Wearing parts are usually limited to those underlined and should be stocked.
41	1	423066	STRIPPER #2	
42	1	423048	HANGER ASSEMBLY	
43	2	423116	NEEDLE BEARING HK 2220	
44	1	023672	CLUTCH PLUG ASSEMBLY	
45	1	080254	ROLL PIN 3/16 DIA X 5/8 LONG	
46	1	422647	EXT SPRING LEE #LE-075E-01	
47	1	023654	SPRING, SPECIAL	
48	1	423126	RELEASE LEVER	
49	1	256747	SHCS, M4 X 16	
50	1	423482	EXTENSION SPRING LEE #LE-034C-6	
51	1	423475	BEARING SPACER	
52	1	162404	DOWEL PIN, Ø6X28	
53	1	023709	RIVET	
54	1	424032	INSTRUCTION LABEL	

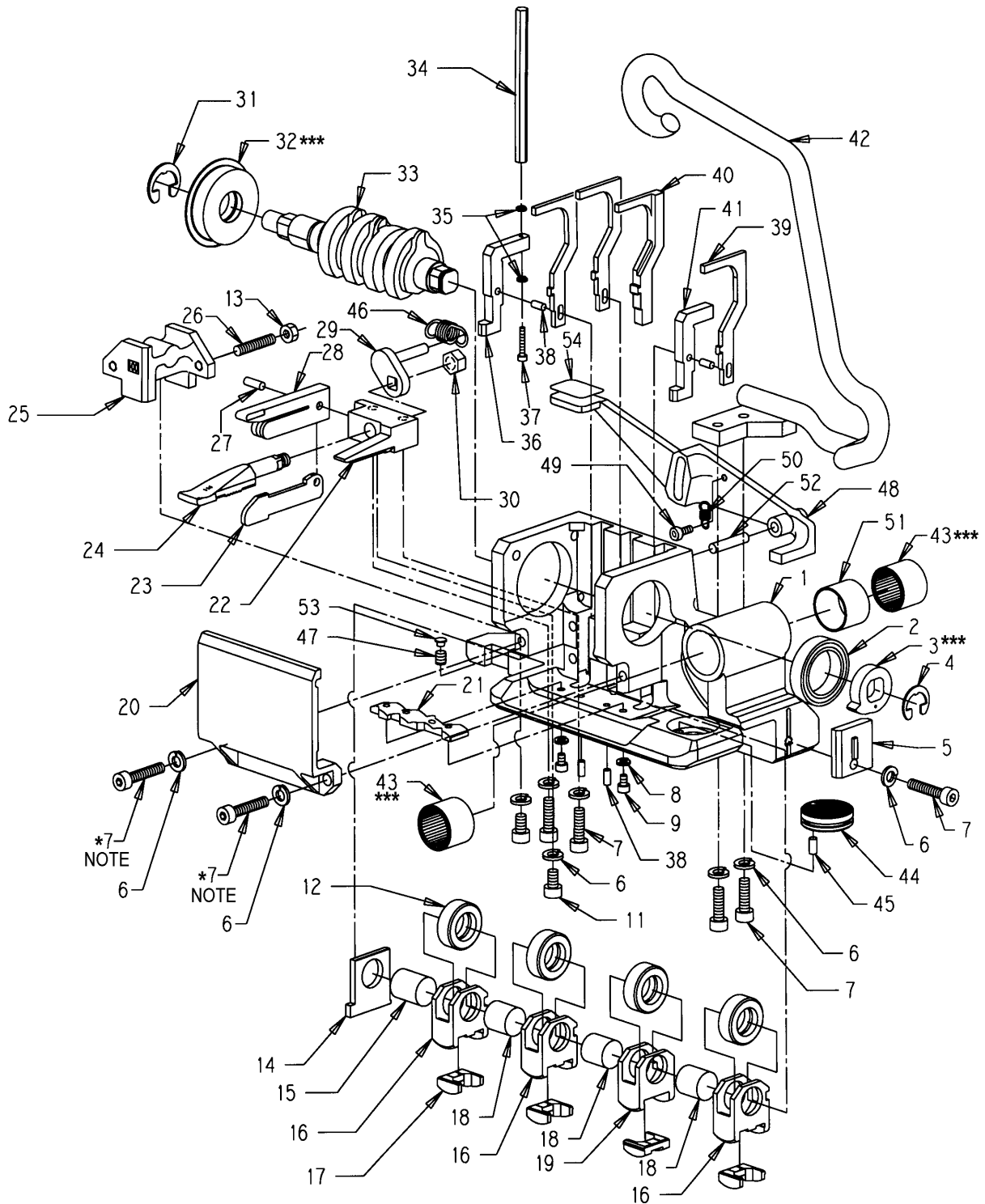

* Secure with Loctite #242.

*** Lubricate with Molith No. 2 or Lubriplate 3000W.

● Lubricate all other moving parts with V4 machine oil.

NOTE: Socket head cap screws (Key 7) which secure the die cover (Key 20) must be torqued to 110-125 lb-in (12.4-14.1 Nm).

PARTS LIST, SEALER MOTOR ASSEMBLY, Part No. 423115

* Items which are not part of motor assembly.

<u>KEY</u>	<u>QTY.</u>	<u>PART NO.</u>	<u>DESCRIPTION</u>
101*	1	423001	SEALER GEARCASE COVER
102*	1	423124	NEEDLE BEARING BK1210
103*	1	306329	NEEDLE BEARING BK1512
104*	1	306330	NEEDLE BEARING BK 1516
105*	3	010037	SHCS M6 X 20
106*	10	010077	LOCK WASHER M6
107*	1	423108	INNER RACE
108*	1	423087	IDLER GEAR 39T
109*	1	090486	DOWEL PIN M4 X 22
110	1	423110	IDLER PINION 7T
111	1	423494	SEALER IDLER ASSEMBLY
112	1	426182	INNER RACE
113	1	426183	INNER RACE, IR 8 X 12 X 10
116	3	423060	IDLER GEAR
117	1	423011	THRUST WASHER
119	1	174140	SSS, M5 X 20
120	1	423059	RING GEAR 48T
121	1	423002	SEALER GEAR CASE
123	1	092772	O-RING #014
124	1	423040	MOTOR HOUSING (SEALER)
125	1	306334	O-RING #33
126	1	256717	BALL BEARING FAF 9101-PP
127*	1	306332	INNER RACE, IR 12 X 15 X 12
128*	1	423109	DRIVE GEAR (34T)
<u>130</u>	<u>7</u>	<u>306427</u>	<u>VANE</u>
<u>131</u>	<u>1</u>	<u>423489</u>	<u>FRONT PLATE</u>
133	1	423085	ROTOR ASSEMBLY
134	1	282490	ROLL PIN DIA 3 X 12
135	1	424344	DOWEL PIN DIA 1/8 X 1.5 INCH
<u>136</u>	<u>1</u>	<u>423488</u>	<u>BACKING PLATE</u>
137	2	091208	O-RING, #032
138	1	031996	BALL BEARING, FAF #200-PP
139	2	306425	BELLEVILLE SPRING WASHER #B1750-057
140	1	423077	END CAP (SEALER)
141	4	269490	SHCS M6 X 100
142	1	423490	CYLINDER
144*	1	423476	GUARD
145*	2	165437	SHCS M6 x 10
146*	3	174149	SHCS, M6 X 25

- When ordering parts, please show tool model, part number and description.
- Standard hardware parts may be obtained from any local hardware supply.
- Wearing parts are usually limited to those underlined and should be stocked.



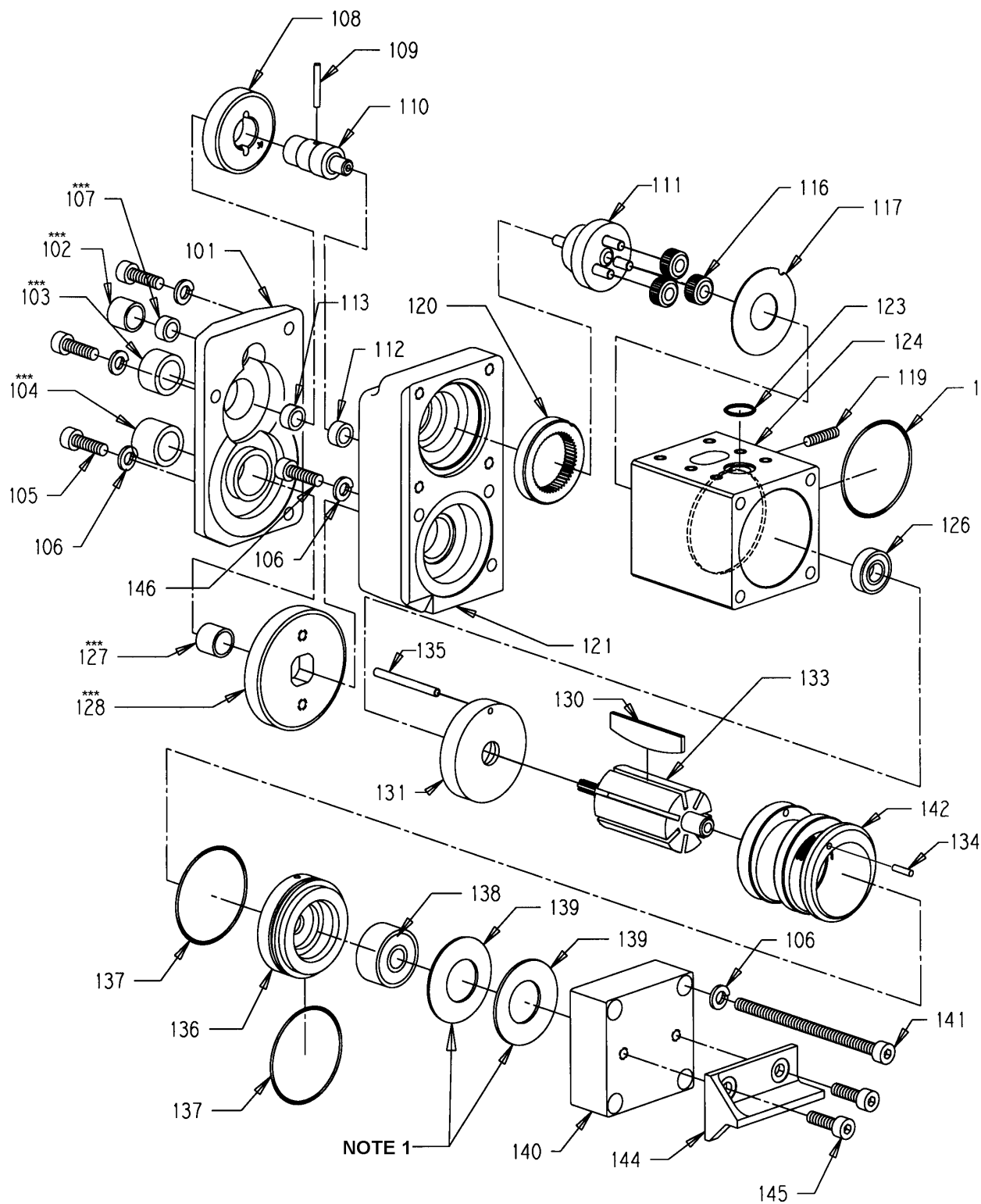

*** Lubricate with Molith No. 2 or Lubriplate 3000W.

NOTES:

1. Washers to be placed back to back with cupped shape outwards) (.

PARTS LIST, LIFTER HANDLE ASSEMBLY

<u>KEY</u>	<u>QTY.</u>	<u>PART NO.</u>	<u>DESCRIPTION</u>
201	1	306483	COUPLING, IN-LINE, MALE SIDE
202	1	306337	TUBING
203	1	422644	CIRCLIP #8
204	1	273822	FITTING
205	1	423097	LIFT HANDLE
206	2	010045	SHCS M6 X 35
207	4	010077	M6 LOCKWASHER
208	2	423119	DU BUSHING, GARLOCK #MB 1210 DU
209	1	423078	PISTON HOUSING
210	1	000884	WOODRUFF KEY
211	1	423096	HANDLE LEVER
212	1	422930	PISTON
213	1	023721	SPIROL PIN 5/32 DIA X 11/16 LG
214	1	023713	O-RING #219
215	1	422929	PLUG
216	1	423091	LINK
217	1	004167	TRUARC
218	1	010037	SHCS M6 X 20
219	1	023658	SPRING
220	1	162374	SHCS, M6 X 30 (FULL THREAD)

- When ordering parts, please show tool model, part number and description.
- Standard hardware parts may be obtained from any local hardware supply.
- Wearing parts are usually limited to those underlined and should be stocked.

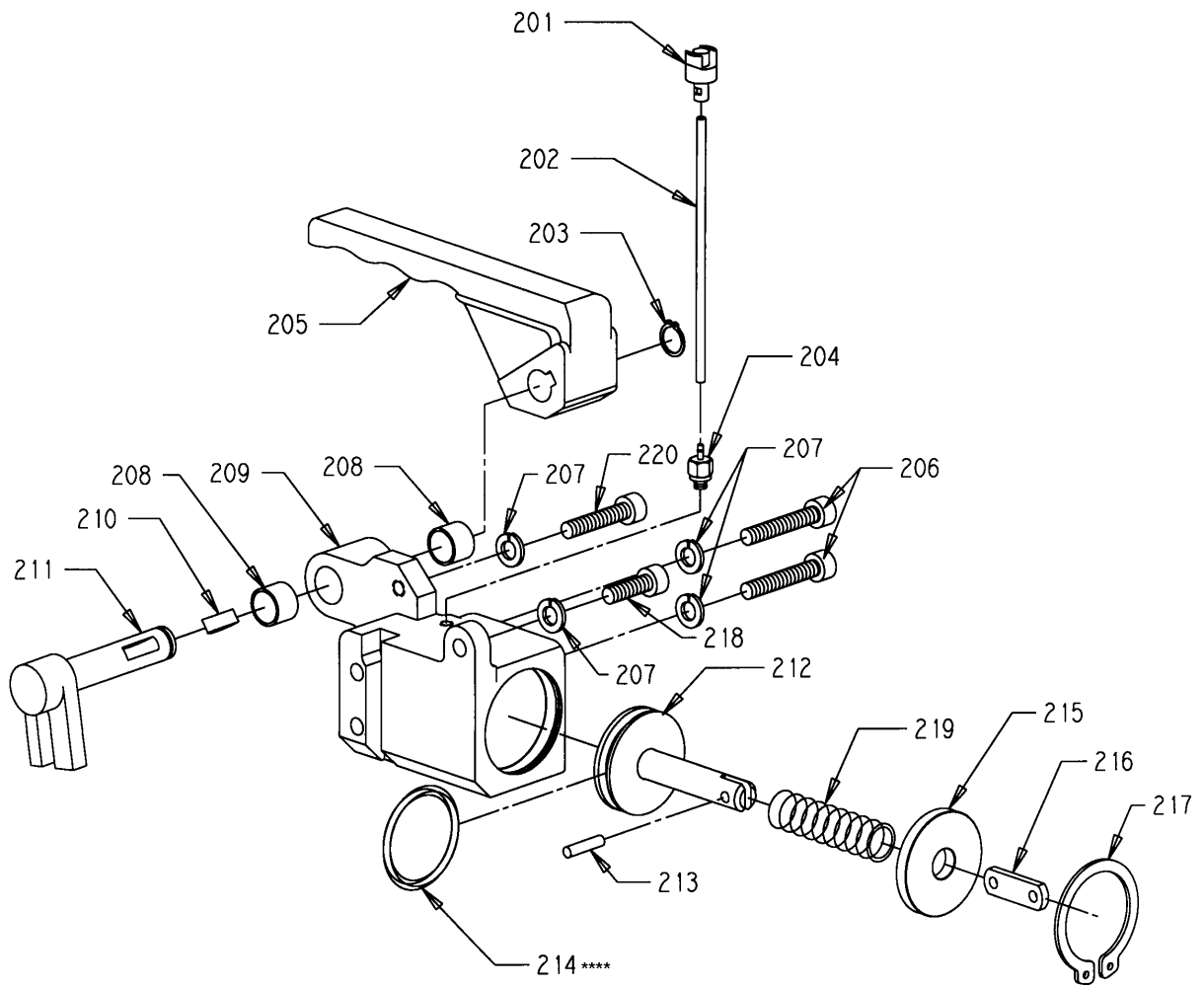

**** Lubricate O-Ring with White (Lubriplate) grease.

<p>⚠ WARNING</p> <p>Inspect all parts daily and replace them if they are worn or broken. Failure to do this can affect a product's operation and could result in serious personal injury.</p>
--

PARTS LIST, VALVE ASSEMBLY

<u>KEY</u>	<u>QTY.</u>	<u>PART NO.</u>	<u>DESCRIPTION</u>
301	7	174149	SHCS M6 X 25
302	16	010077	LOCKWASHER M6
303	1	425417	TENSION LEVER
304	1	425418	SEALER LEVER
305	1	424274	PIVOT PIN
306	1	423092	VALVE HOUSING
307	1	424040	SHSS M4 X 8 W/ NYLON TIP
308	1	162396	TRUARC, #11-420-0060
309	1	004164	O-RING #011
310	1	306338	TRUARC E-RING N5000-43C
311	1	274214	TENSION ADJ SCREW
312	1	008477	1/4 NPT PIPE PLUG
313	1	422757	SCREEN
314	1	020704	HANSEN PLUG
315	1	274442	ADJUSTABLE ELBOW
316	1	306734	3/8 RUBBER BALL
317	1	306337	TUBING
318	1	306483	COUPLING, IN-LINE, FEMALE SIDE
319	1	423076	HANDLE
320	1	423114	NEEDLE BEARING HKO306
321	1	423030	PAWL
323	1	023675	SPRING
324	1	023662	COVER PLATE
325	2	176601	FLAT HD SOC CAP SC M5 X 10
326	1	251255	SHCS M3 X 14
327	1	423070	PAWL LEVER
328	1	423576	SHSS PATCH LOC, M6 X 20
329	1	023659	VALVE SLEEVE, SEALER, BOTTOM
330	7	020699	O-RING #013
331	1	424338	COMPRESSION SPRING, LEE #LC-049E-11MW
332	1	424336	VALVE STEM, SEALER
333	6	020701	O-RING #009
334	1	424337	VALVE SLEEVE, SEALER, MIDDLE
335	1	020660	VALVE SLEEVE, TOP
336	1	023666	VALVE SLEEVE, TENSION
337	3	256747	SHCS M4 X 16
338	1	023670	SHOULDER SCREW
339	1	004131	SPRING, VALVE LATCH
340	1	423029	VALVE PLATE
341	5	010045	SHCS M6 X 35
342	1	015219	1/8 NPT PIPE PLUG
344	1	425416	LATCH, TENSION VALVE
345	1	423031	CONNECTOR PLATE
346	1	286373	INFO SIGN (3 ICON)
347	1	422188	WARNING SIGN
348	3	092772	O-RING #014
349	1	008798	TAG
350	1	023665	VALVE STEM, TENSION
351	1	020665	VALVE SPRING
352	2	251249	SHCS, M6 X 50
353	1	306360	FOAM INSERT
354	1	423000	NAMEPLATE (100)
		423101	NAMEPLATE (114)
456	1	425411	MOUNTING BLOCK
457	1	425412	SPACER
458	1	425413	LOCK-OUT ARM
459	1	425419	COMPRESSION SPRING
460	1	424737	DOWEL PIN, 6 X 12
461	2	162498	ROLL PIN, 3 X 12
462	2	010037	SHCS, M6 X 20

WARNING

Inspect all parts daily and replace them if they are worn or broken. Failure to do this can affect a product's operation and could result in serious personal injury.

- When ordering parts, please show tool model, part number and description.
- Standard hardware parts may be obtained from any local hardware supply.

NOTES:

1. Install middle valve sleeve (Key 334) with slot facing valve plate (key 340).
2. Never connect air to manifold when it has been disassembled from the tool.
3. Lubricate all O-rings with white (Lubriplate) grease.
4. Install dowel pin (Key 460) with tapered end in to the lock-out arm (Key 458) using Loctite #609 or equivalent.

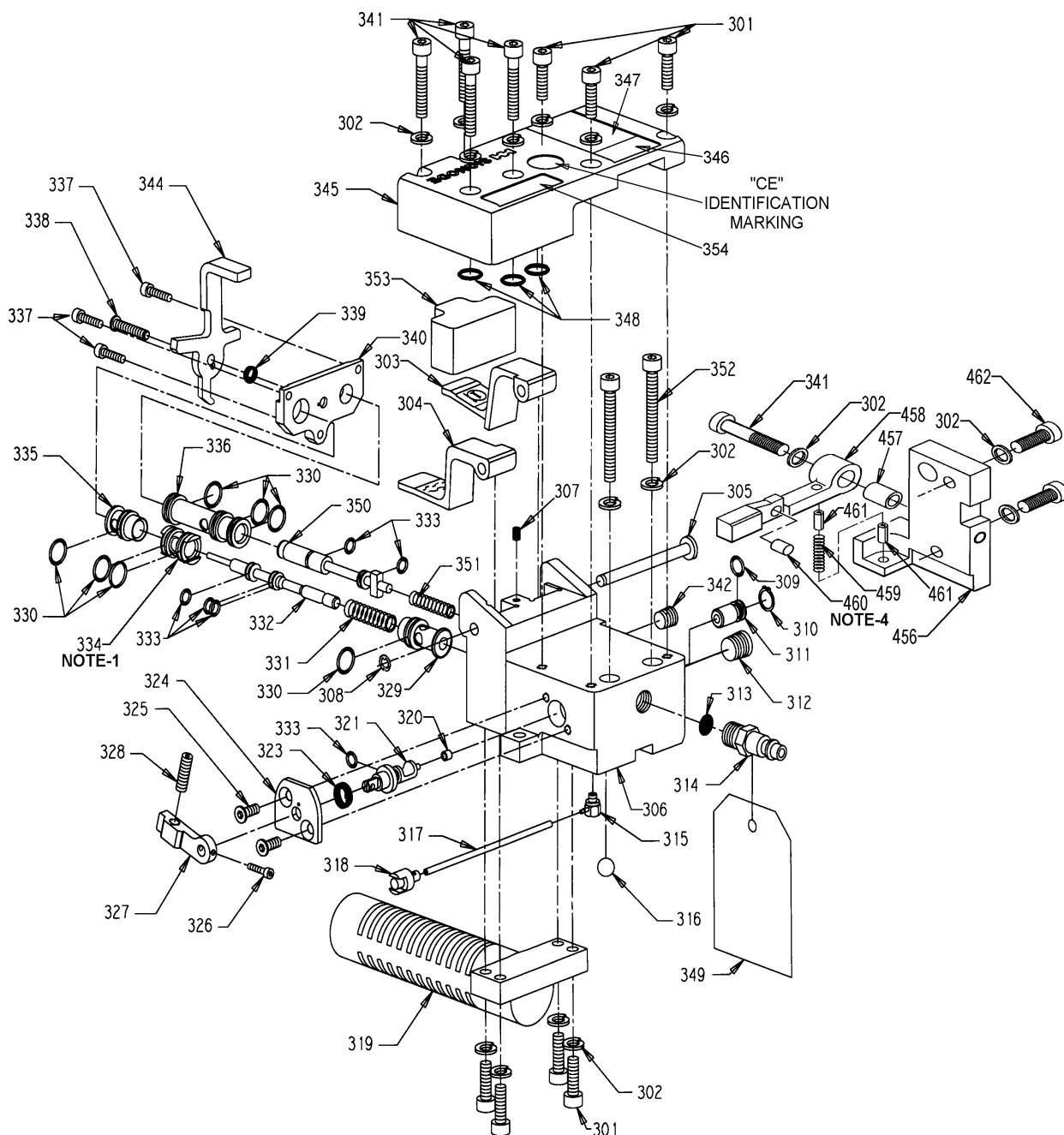

PARTS LIST, TENSION MOTOR ASSEMBLY

<u>KEY</u>	<u>QTY.</u>	<u>PART NO.</u>	<u>DESCRIPTION</u>
401	1	423064	BEARING CAP
402	1	306469	THRUST WASHER
403	1	008407	RING GEAR
404	1	425404	DOWEL PIN (SPECIAL)
405	1	306430	MIDDLE HOUSING
406	1	306448	BALL BEARING NTN #6906
407	3	306436	IDLER GEAR ASSEMBLY (17T)
409	1	423575	IDLER CARRIER ASSEMBLY
411	1	282490	ROLL PIN DIA 3 X 12
412	1	423013	CYLINDER
413	<u>7</u>	<u>306427</u>	<u>VANE</u>
415	1	423486	ROTOR ASSEMBLY
417	<u>1</u>	<u>423489</u>	<u>FRONT PLATE</u>
418	1	160322	ROLL PIN DIA 3 X 24
419	1	256717	BALL BEARING, FAF 9109-PP
420	1	092772	O-RING #014
421	1	306334	O-RING #33
422	1	423038	MOTOR HOUSING
423	2	091208	O-RING #32
424	<u>1</u>	<u>423488</u>	<u>BACKING PLATE</u>
425	1	031996	BALL BEARING, FAF #200-PP
426	2	306425	BELLEVILLE SPRING WASHER #1750-057
427	1	306424	END CAP
428	4	306452	SHCS M6 X 110
429	4	010077	LOCKWASHER, M6
430	1	425379	WASHER
431	1	162382	LOCKWASHER, M4
432	1	162383	SHCS, M4 X 8

- When ordering parts, please show tool model, part number and description.
- Standard hardware parts may be obtained from any local hardware supply.
- Wearing parts are usually limited to those underlined and should be stocked.



PARTS LIST, TENSIONER GEAR HOUSING ASSEMBLY

<u>KEY</u>	<u>QTY.</u>	<u>PART NO.</u>	<u>DESCRIPTION</u>
451	1	423019	GEAR HOUSING
452	1	008536	WASHER
453	1	008524	RING GEAR
454	1	008534	SPACER RING
455	3	008815	IDLER GEAR ASSEMBLY
456	1	023747	WORM ASSEMBLY
457	1	023754	BEARING
458	1	008751	NEEDLE BEARING
459	1	006639	COTTER PIN 1/16 DIA X 3/4 LONG
460	1	008581	LOCK SCREW
461	3	007031	BALL BEARING KKP16A
462	1	423005	DRIVE SHAFT
<u>463</u>	<u>1</u>	<u>023748</u>	<u>WORM WHEEL</u>
464	2	007023	KEY
465	1	007027	O-RING #141
466	1	423067	HOUSING COVER
467	2	010037	SHCS M6 X 20
468	1	254411	SHCS M6 X 14
469	3	010077	LOCKWASHER M6

- When ordering parts, please show tool model, part number and description.
- Standard hardware parts may be obtained from any local hardware supply.
- Wearing parts are usually limited to those underlined and should be stocked.



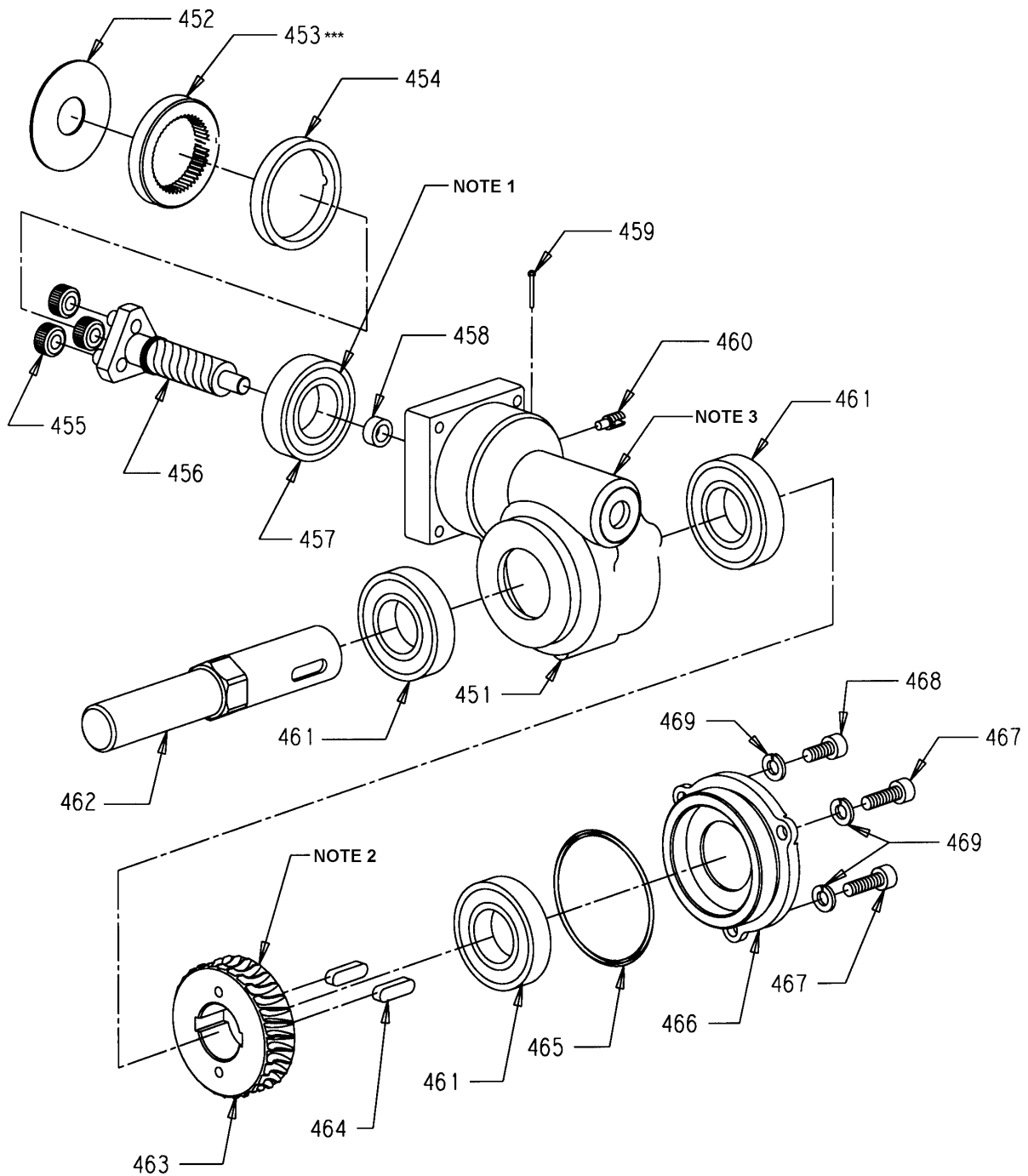

*** Lubricate with Molith No. 2 or Lubriplate 3000W.

NOTES:

1. Wide shoulder of Bearing (Key 457) should face Gear Housing (Key 451).
2. Letter "E" stamped in Worm Wheel should face Housing Cover (Key 466).
3. Gear Housing (Key 451) should be filled 1/3 full with K55 grease.
4. Tensioner Gear Housing assembly and Tension Motor assembly (Pages 22 & 23) may be purchased complete as Tensioner Unit, Signode Part No. 423120.

PARTS LIST, FEED DRIVE HOUSING ASSEMBLY

<u>KEY</u>	<u>QTY.</u>	<u>PART NO.</u>	<u>DESCRIPTION</u>
501	1	423004	FEEDWHEEL SHAFT
<u>502</u>	<u>1</u>	<u>423055</u>	<u>FEEDWHEEL</u>
503	1	423015	OUTER LINK (100)
	1	423056	OUTER LINK (114)
504	3	010077	LOCKWASHER 6MM
505	3	174149	SHCS M6 X 25
506	1	423358	SHSS M6 X 40
507	1	423006	FEEDWHEEL GEARCASE
508	2	423003	REVERSING GEAR
509	1	422754	NEEDLE BEARING #BK1812
512	1	005466	FLEXLOC NUT M6
513	2	172076	DOWEL PIN DIA 6 X 36
514	1	423491	BEARING
515	1	422649	NEEDLE BEARING BK2516
516	1	423358	SHSS M6 X 40
517	1	256747	SHCS M4 x 16

- When ordering parts, please show tool model, part number and description.
- Standard hardware parts may be obtained from any local hardware supply.
- Wearing parts are usually limited to those underlined and should be stocked.

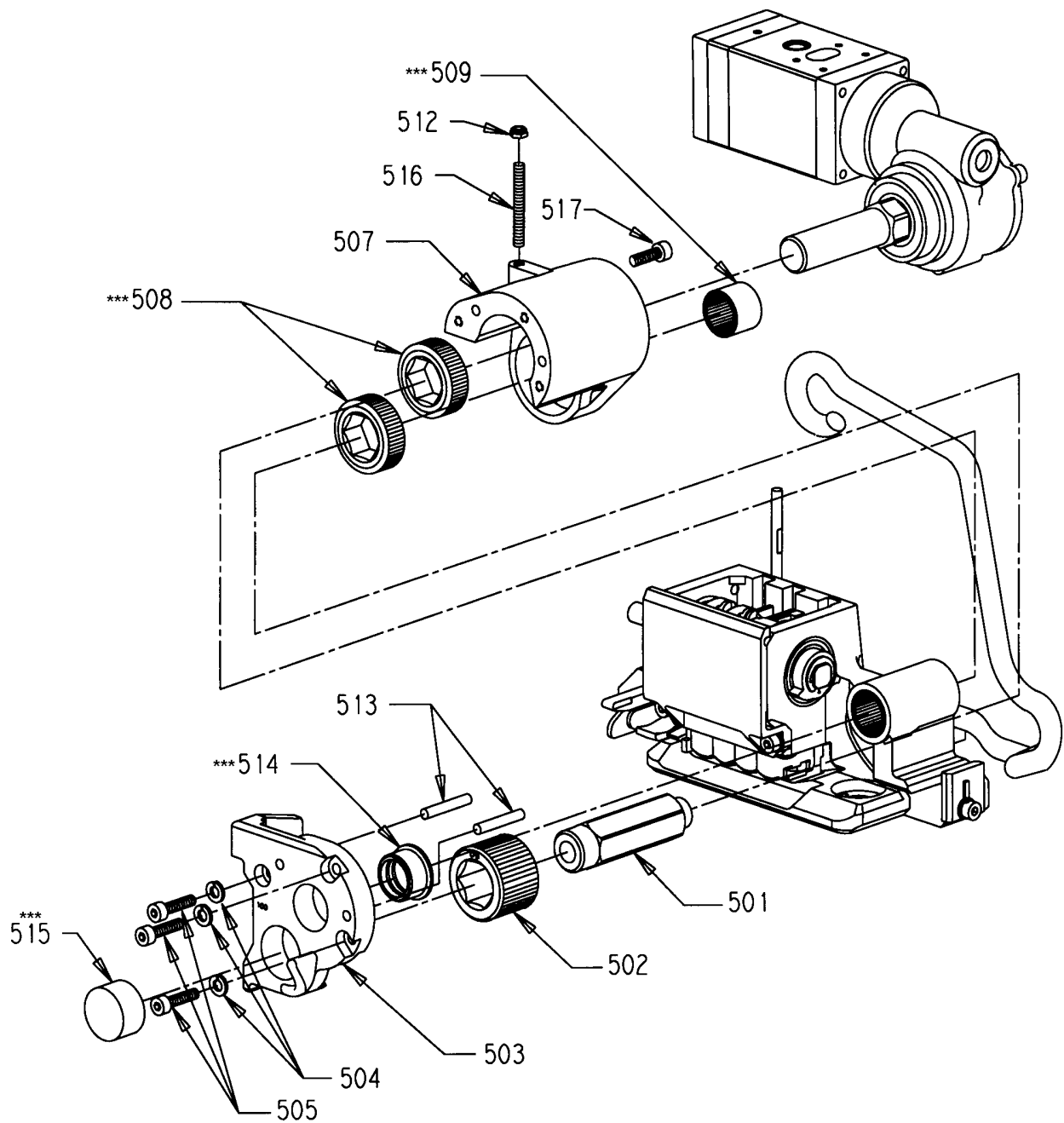

*** Lubricate with Molith No. 2 or Lubriplate 3000W.

⚠ WARNING
 Inspect all parts daily and replace them if they are worn or broken. Failure to do this can affect a product's operation and could result in serious personal injury.

TROUBLESHOOTING

The following items are the most common tool symptoms if problems occur. For symptoms or remedies not shown, contact your Signode service representative for additional information and details. The following tool symptoms are shown in this manual:

- #1 - Difficult strap slack removal.
- #2 - Tool does not tension when tension lever is pressed.
- #3 - Tool does not complete sealing cycle.
- #4 - Strap does not cut after sealing cycle.
- #5 - Bottom strap breaks during sealing.

#1 SYMPTOM: Difficult strap slack removal.	
CAUSE	REMEDY
<ol style="list-style-type: none"> 1. Improper strap being used. 2. Ratchet wheel mechanism worn or broken. 	<ol style="list-style-type: none"> 1. Check that waxed strapping of the correct width is being used. 2. Repair or replace ratchet wheel components.

#2 SYMPTOM: Tool does not tension when tension lever is pressed.	
CAUSE	REMEDY
<ol style="list-style-type: none"> 1. Stop button in down position. 2. Improper strap being used. 3. Feedwheel clearance incorrectly set. 4. Dirty or worn feedwheel. 5. Straps improperly aligned. 6. Feedwheel not rotating. 	<ol style="list-style-type: none"> 1. Pull up Stop button. 2. Check that waxed strapping of the correct width is being used. 3. Check feedwheel clearance, adjust if necessary. 4. Clean or replace feedwheel as required. 5. Reload and realign straps. 6. Inspect tensioner gear housing for broken parts.

#3 SYMPTOM: Tool does not complete sealing cycle.	
CAUSE	REMEDY
<ol style="list-style-type: none"> 1. Improper strap being used. 2. Worn or broken dies and/or punch. 	<ol style="list-style-type: none"> 1. Check that waxed strapping of the correct width and thickness is being used. 2. Inspect dies and punch replace as required.

#4 SYMPTOM: Strap does not cut after sealing cycle.	
CAUSE	REMEDY
<ol style="list-style-type: none"> 1. Improper cutter clearance. 2. Worn or broken cutter blade. 	<ol style="list-style-type: none"> 1. Inspect strap for proper cut-off, adjust cutter clearance if necessary. 2. Inspect cutter blade, replace or rotate as required.

#5 SYMPTOM: Bottom strap breaks during sealing.	
CAUSE	REMEDY
<ol style="list-style-type: none"> 1. Improper cutter clearance. (Strap breaks at cutter.) 2. Tension set too high. (Strap breaks at the joint area.) 3. Worn or broken dies and/or punch. (Strap breaks at the joint area.) 4. Package has sharp corners. (Strap breaks at package corner.) 	<ol style="list-style-type: none"> 1. Inspect strap for proper cut-off, adjust cutter clearance if necessary. 2. Reduce strap tension. 3. Inspect dies and punch replace as required. 4. Lower strap tension or use package corner protectors.

CHANGING SPC STRAP SIZE

The following table illustrates the unique parts to a particular strap size for the SPC tool. If the strap size of the tool is to be changed, this table must be used to coordinate all the respective parts which must be replaced.

NOTE: To convert an SPC-114 to SPC-100, order "SPC-100 Kit" Signode Part No. 423100. This kit contains all the necessary parts shown below.

WARNING

Do not attempt to convert a tools strap size without replacing all of the specified parts for the conversion. Failure to replace all required parts may cause severe personal injury.

UNIQUE PARTS TO SPC STRAP SIZES

KEY	QTY	DESCRIPTION	SPC-114	SPC-100
5	1	Front Strap Guide	423050**	423050**
14	1	Cutter	423075	424072
17	4	Die	423074	423374
21	1	Punch	423073	423373
23	1	Strap Latch, Movable	423080	423081
25	1	Rear Strap Guide	423042**	423042**
354	1	Nameplate	423000	423101
503	1	Outer Link	423056	423015

** Reversible parts, position guide on tool with proper strap size displayed.

OPTIONAL TOOL HANGERS

These optional tool hangers replace the standard handle using the existing hanger hardware.

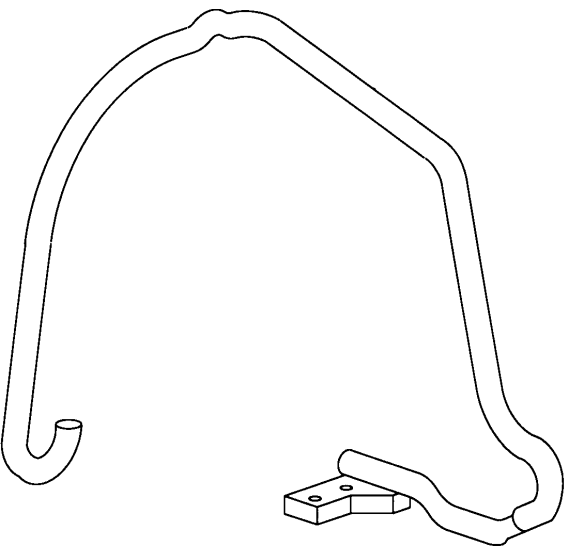
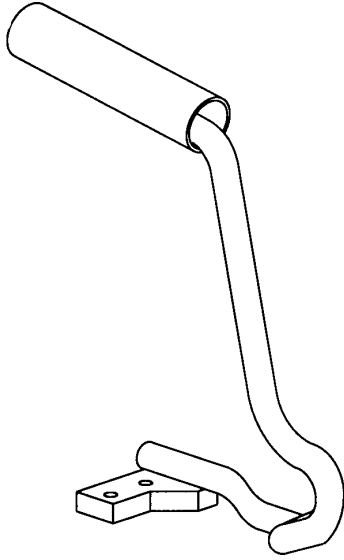
<p>3-WAY HANGER Part No. 423057</p> <p>For use with horizontal, vertical and top strapping applications.</p>	<p>CARRYING HANDLE Part No. 423084</p> <p>For use with mobile applications.</p>
	



EU Declaration of Conformity
The Supply of Machinery (safety) Regulations
1992 (S.I. 1992/3073)

It is hereby declared that the undermentioned machinery has been designed and constructed to comply with the health and safety requirements defined in EC Directive 89/392/EEC

Machine Supplier: Signode, Division of ITW Ltd.
Queensway, Fforestfach
Swansea SA5 4ED

Machine Description: SPC Series

Machine Type: Pneumatic Combination Hand Strapping tool.

Provisions with which machine complies:

89/392/EEC, 91/368/EEC

Harmonized EuroNorms with which machine complies:

EN 292:1, EN 292:2, EN 294, EN 349

Technical Standards with which machine complies:

NA

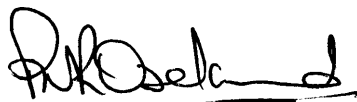
Signature:  Date: 1 APRIL 2000
(Peter Oseland)

SIGNODE NEW TOOL WARRANTY

Signode Engineered Products Warrants that a new Signode strapping tool will operate per functional specifications for a period of sixty (60) days after the date of shipment to the owner's place of business. Normal wearing parts, as outlined in the Operation, Parts & Safety manual, are covered by a thirty (30) day warranty unless, in Signode's judgement, these parts have been subjected to abnormal or extreme usage. Signode's sole liability hereunder will be to repair or replace, without charge, F.O.B. Signode's Glenview, Illinois plant, any tool which proves to not operate per functional specifications within the stated period. Signode reserves the right to replace any tool which proves not to operate per functional specifications with a new or like-new tool of the same model if in Signode's judgement such replacement is appropriate. Any new replacement tool provided to an owner will carry a full sixty (60) day warranty. Any warranty repaired tool or like-new replacement tool will carry a warranty for the balance of the time remaining on the initial sixty (60) day warranty. This warranty will be extended to compensate for the time the tool is in Signode's possession for warranty repairs.

This warranty is void as to any tool which has been: (I) subjected to mis-use, misapplication, accident, damage, or repaired with other than genuine Signode replacement parts, (II) improperly maintained, or adjusted, or damaged in transit or handling; (III) used with improperly filtered, unlubricated air or improper strapping material, (IV) in Signode's opinion, altered or repaired in a way that affects or detracts from the performance of the tool.

SIGNODE MAKES NO WARRANTY, EXPRESSED OR IMPLIED, RELATING TO MERCHANTABILITY, FITNESS OR OTHERWISE EXCEPT AS STATED ABOVE AND SIGNODE'S LIABILITY AS ASSUMED ABOVE IS IN LIEU OF ALL OTHERS ARISING OUT OF OR IN CONNECTION WITH THE USE AND PERFORMANCE OF THE TOOL. IT IS EXPRESSLY UNDERSTOOD THAT SIGNODE SHALL IN NO EVENT BE LIABLE FOR ANY INDIRECT OR CONSEQUENTIAL DAMAGES INCLUDING, BUT NOT LIMITED TO, DAMAGES WHICH MAY ARISE FROM LOSS OF ANTICIPATED PROFITS OR PRODUCTION, SPOILAGE OF MATERIALS, INCREASED COSTS OF OPERATION OR OTHERWISE.

Considerable effort has been made to ensure that this product conforms to our high quality standards. However, should you experience any difficulties, please contact your Sales Representative providing samples and the manufacturing code specified on the tool.

Thank you for your help.

SIGNODE ENGINEERED PRODUCTS
Hand Tool Division
3620 W. Lake Avenue, Glenview, Illinois 60025

PART #	DESCRIPTION	AREA OF USE
LUBRICANTS		
177029	BROWN K-55 GREASE	CLUTCH DRIVES, INTERNAL GEARS, GEAR SETS
422792	WHITE LUBRIPLATE GR-132 GREASE	PNEUMATIC PARTS, AIR CYLINDERS, AIR VALVES, O-RINGS
422793	BLACK LUBRIPLATE 3000W GREASE	MOVING INTERNAL PARTS, JAWS, LINKS
432322	EP ACCROLUBE GREASE	HIGH FRICTION CONTACT PARTS
008556	LS-1236 AIR LINE OIL	AIR MOTORS, AIR VALVES
ADHESIVES		
422794	LOCTITE #222, PURPLE	LOW STRENGTH, SCREWS 1/4" (6MM) OR SMALLER SIZES
422795	LOCTITE #242, BLUE	MEDIUM STRENGTH, SCREWS 5/16" (8MM) OR LARGER SIZES
422796	LOCTITE #271, RED	HIGH STRENGTH, SEMI-PERMANENT SCREW APPLICATION
422797	LOCTITE #609, GREEN	PERMANENT, CURVED SURFACE PART CONTACT
274111	LOCTITE #380, BLACK MAX	PERMANENT, FLAT SURFACE PART CONTACT
CLEANING BRUSHES		
023963	SMALL BRUSH	FEEDWHEEL & GRIPPER TEETH
269589	LARGE BRUSH	FEEDWHEEL & GRIPPER TEETH